

ZERO

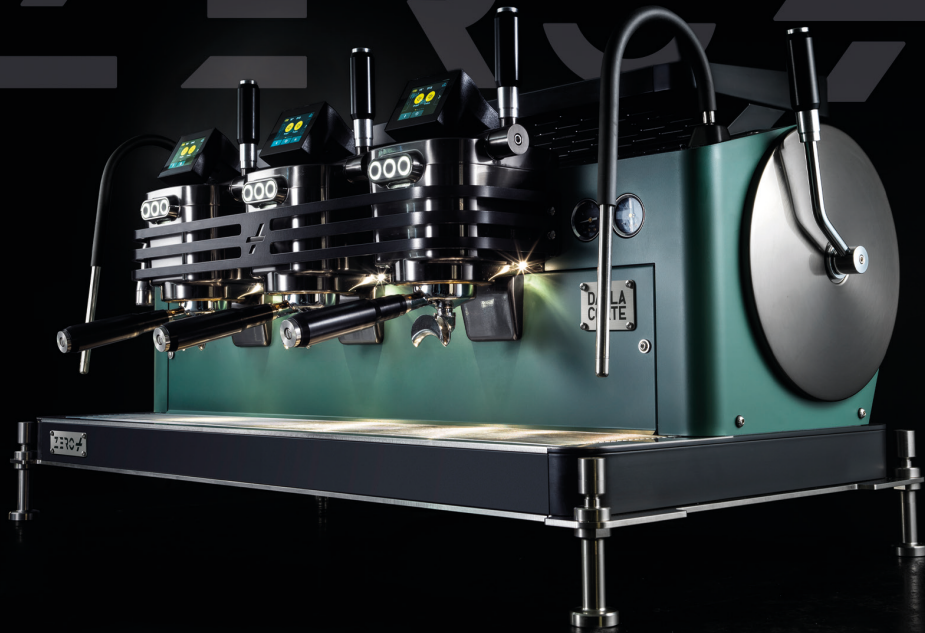

DALLA
CORTE

ART

THE ART OF EXTRACTION

1. CREATE YOUR PROFILE

From the digital menu or with the side lever, you have the freedom to shape the extraction step by step, creating a profile that reflects your vision of coffee.

2. SAVE YOUR RECIPE

Your personal coffee menu: the extraction profiles can be saved and named in Zero Plus' library.

3. REPLICATE YOUR SHOT

Unlimited creative freedom: saved profiles ensure that every cup is perfect, identical to the last, with consistent extraction parameters.

**CREATE
YOUR
PROFILE**

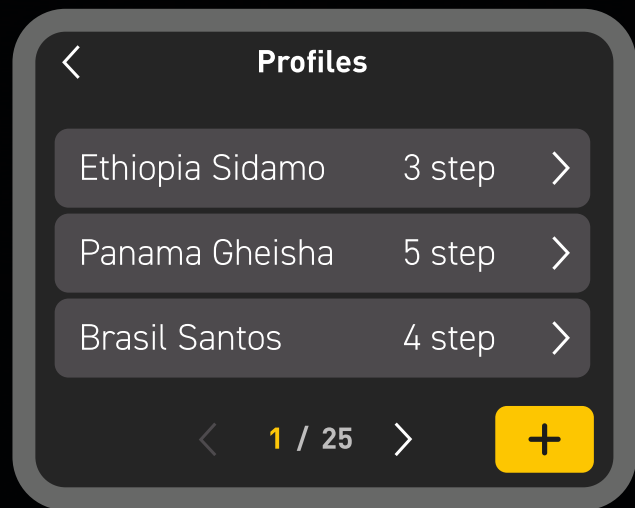

TECHNOLOGY

FLIP THE RULES

At Dalla Corte, we like to do things our own way, rewriting the rules of espresso. With Zero Plus, we redefine the limits of extraction once again.

1. DIGITAL FLOW REGULATION (DFR)

Control water flow with precision through the digital settings, or follow your instincts with the freestyle mode. From 3 to 9 grams of water per second, unlock the full aromatic potential of every single origin or blend.

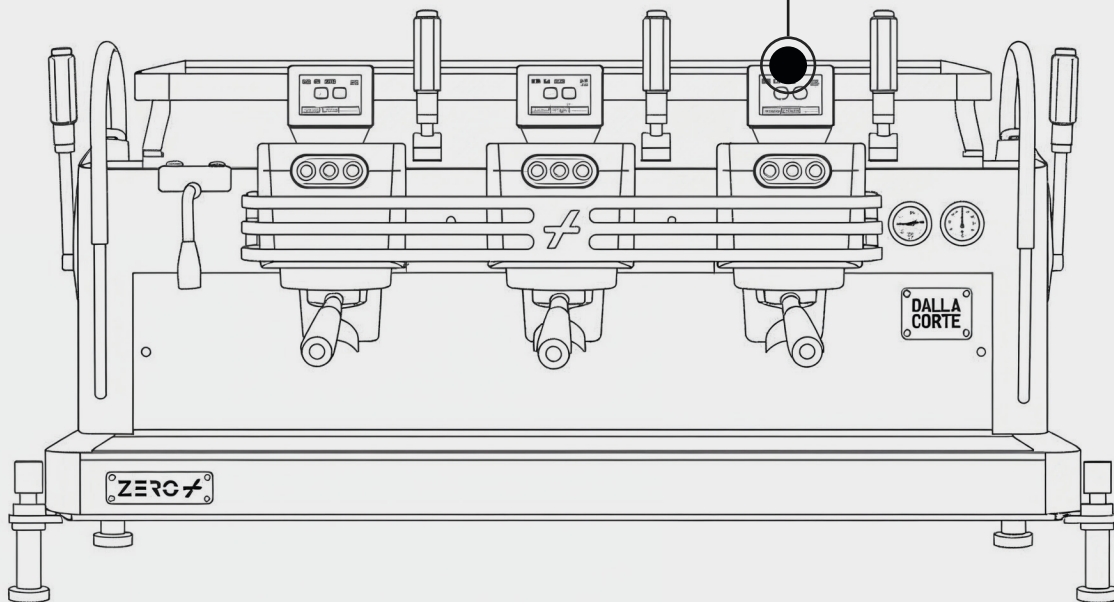
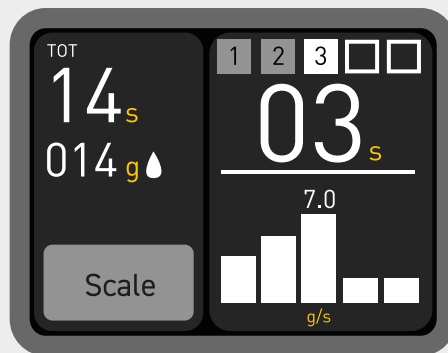

2. INDEPENDENT INTEGRATED MULTI-BOILER

Zero Plus' core technology is the Multiboiler system. Each group can be managed independently and contains a 0,75 L integrated boiler, that heats up cold water directly from the supply and ensures total control over temperature with a precision of 0.1° C.

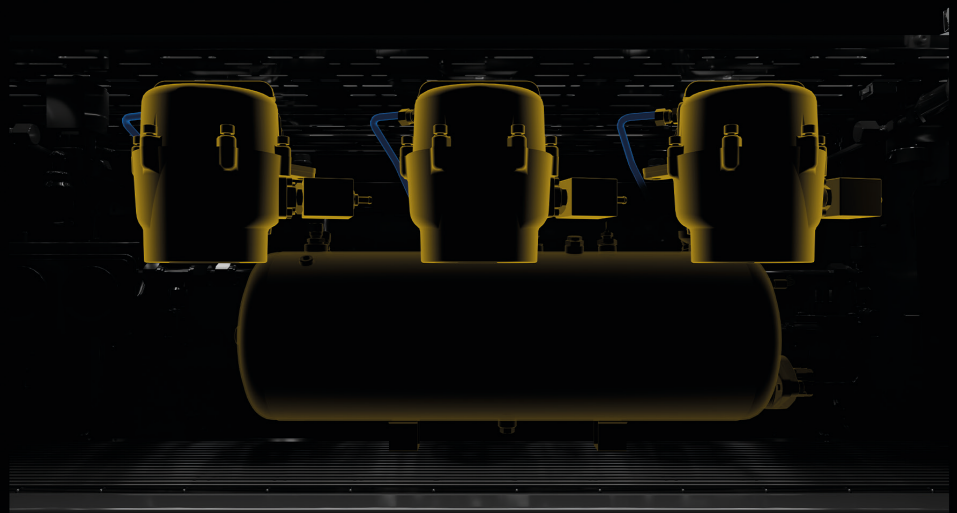

CONTROL

Accurate temperature regulation (0,1°C).

ENERGY SAVING

Possibility to switch off unused groups.

FLEXIBILITY

Dedicated extractions for different coffees.

MAINTENANCE

Quick access without stopping the machine.

CONSISTENCY

Maintaining temperature without fluctuations.

3.54 MM PORTAFILTER

Precision starts at the base. Our 54mm portafilter has been the Dalla Corte standard for years.

It reduces the risk of channeling, ensures optimal pre-infusion, and most importantly, enhances the extraction of your coffee's aromas.

The result: a full-bodied, perfectly balanced espresso every time.

CRAFTED FOR AROMA

The 54mm portafilter creates a taller coffee puck with the same dose, allowing for greater aroma extraction and more body.

SMALLER AREA
SMALLER FORCE



4. REAL TIME WEIGHT

All the tools you need are built in – free from external scales, thanks to our integrated virtual weighing system. The precision of your espresso is now an internal feature.

Integrated directly into the machine, Real Time Weight eliminates the need for external scales and streamlines workflow.

You can monitor and control both the dose and the final extraction weight in real time, ensuring absolute control over every shot.

Your workstation stays cleaner, your workflow faster, and precision is always guaranteed.

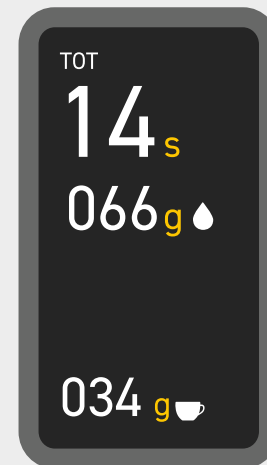

BUILT-IN ACCURACY

No external scales needed: monitor and control your dose and final extraction weight directly from the group's screen, in real time.

5.DC SYSTEM

THE TECHNOLOGICAL ECOSYSTEM FOR IMPECCABLE RESULTS

DC System is our ecosystem of patented technologies designed to simplify the barista's workflow.

- **AUTOMATIC GRIND ADJUSTMENT**
- **CONSISTENT EXTRACTION QUALITY**
- **AUTOMATIC MILK FROTHING**



- 0 - GCS

GRINDER CONTROL SYSTEM

Zero Plus connects with the coffee grinder (DC ONE or DC TWO) and automatically corrects grind size and dose based on extraction.

The smartest way to control different coffee selections and always ensure the perfect shot.

OCS

ONLINE CONTROL SYSTEM

Manage all your machines remotely, quickly and easily. With OCS you can monitor extraction parameters, schedule maintenance, and check cleaning status. You can also optimize energy consumption, ensuring operational continuity and consistent quality across all your locations.

DESIGN

DESIGN THAT INSPIRES

Winner of the iF Design Award, Zero Plus represents the perfect mix between design and innovation. Its clean lines encourage interaction between barista and customer. Every detail can be customized - from standard colours to fully tailor-made finishes - transforming the machine into a unique design element that enhances the space and embodies your professional identity.



VERSIONS

ZERO PLUS CLASSIC

High-level performance and multi-boiler technology combined with a one-of-a-kind design.

ZERO PLUS BARISTA

Revolutionize espresso extraction with the Digital Flow Regulation (DFR) technology.



TOTAL WHITE



CHRONO GREY



TOTAL BLACK



TEAL GREEN



ART, TECHNOLOGY, DESIGN

Zero Plus is the fusion of art, technology, and design. Every extraction becomes a controlled and customizable experience, where the barista is the true artist. Real creative freedom lies in control: from the digital menu or with the side lever, you can shape the extraction step by step. With Digital Flow Regulation (DFR), design a unique flavor profile, save it, name it in your personal library, and replicate it consistently.



TECHNICAL SPECIFICATIONS	2 groups	3 groups
Dimensions (l x h x p)	870 x 546 x 550 mm	1100 x 546 x 550 mm
Weight	87 kg	112 kg
Max power	4,9 kW	7 kW
Power supply	400 V 3 N	400 V 3 N
Boiler capacity	7,5 l	13 l
Group head capacity	2 x 0,75 l	3 x 0,75 l

ACCESSORIES	2 groups	3 groups
GCS Grinder Control System	optional	optional
OCS Online Control System	optional	optional
58 mm portafilters	optional	optional