

DALLA
CORTE
MAKE it BETTER



PASSION FOR PRODUCTS PASSION FOR PEOPLE

We all have a passion. Something deep inside that drives us.
Something that makes us who we are.
Something we love.

At Dalla Corte, we are devoted to coffee.

It's our purpose to create the best coffee machines to give you the power
to make the perfect espresso.

Our driving focus is to deliver the simplest, most intuitive and highest
quality solutions to allow our customers to make better coffee every day.

By providing you with the most advanced technology, we are bringing the
most delicious coffee to your cup.

Our promise to you, is that we'll keep on improving by searching for new
things to learn.

Your promise to us, is to always expect the very best from your espresso.

We are Dalla Corte.
We are here to

#MakeItBetter

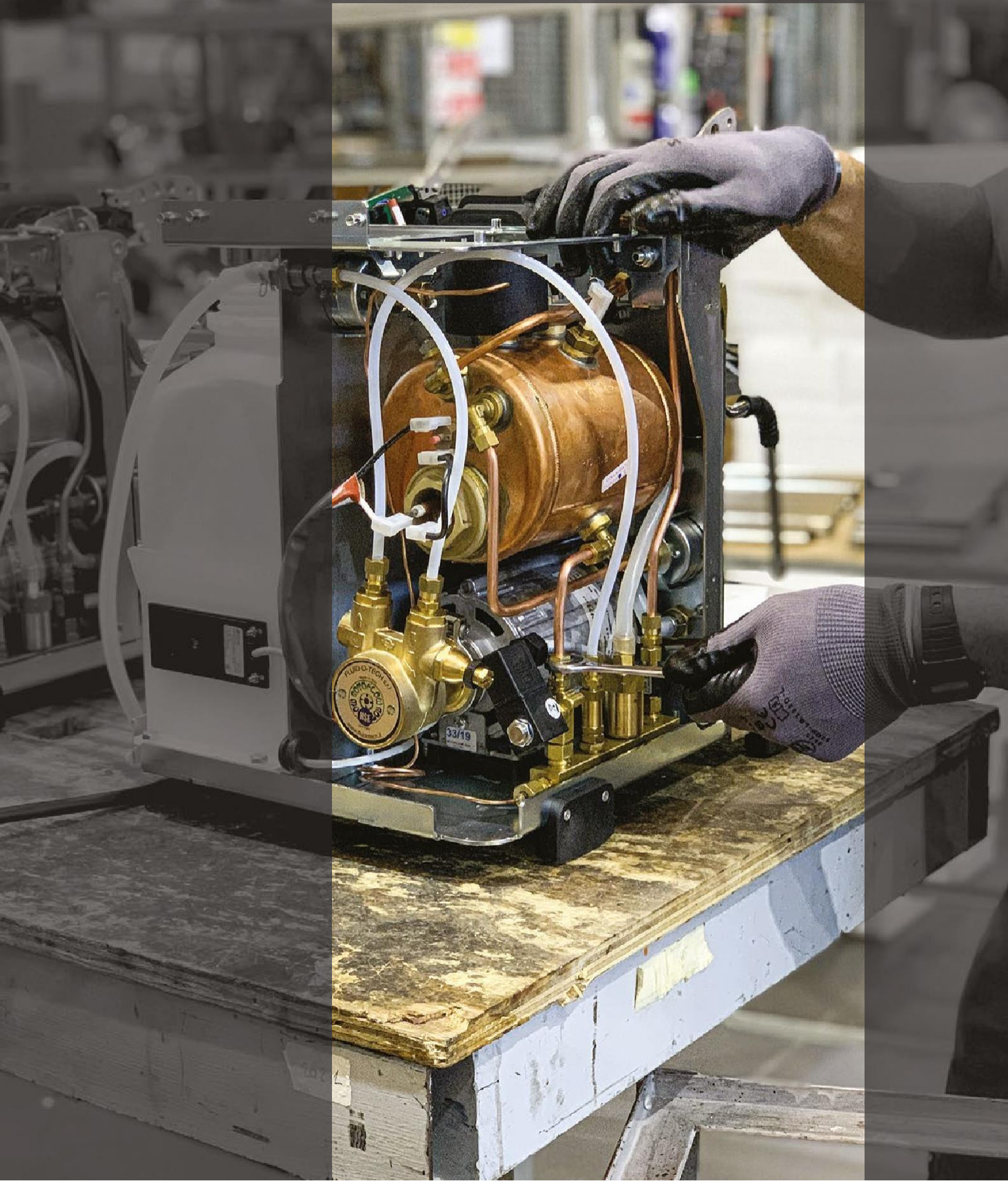



LET'S BUILD YOUR COFFEE SHOP

Our machines are all equipped with amazing technology, making them ideal for any kind of shop. What does your business need?

COFFEE SHOPS



ZERO BARISTA
Groups 2 - 3



ZERO CLASSIC
Groups 2 - 3



XT BARISTA
Groups 2 - 3



XT CLASSIC
Groups 2 - 3



ICON
Groups 2 - 3



MINA
Group 1



MINA SMART BAR
Groups 2 - 3 - 4

HORECA&CHAINS



ICON
Groups 2 - 3



ZERO CLASSIC
Groups 2 - 3



XT CLASSIC
Groups 2 - 3



EVO2
Groups 2 - 3 - 4

HOME&SMALL BUSINESSES

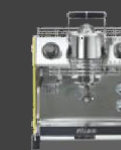

MINA
Group 1



STUDIO
Groups 1



STUDIO AQUA
Group 1



STUDIO

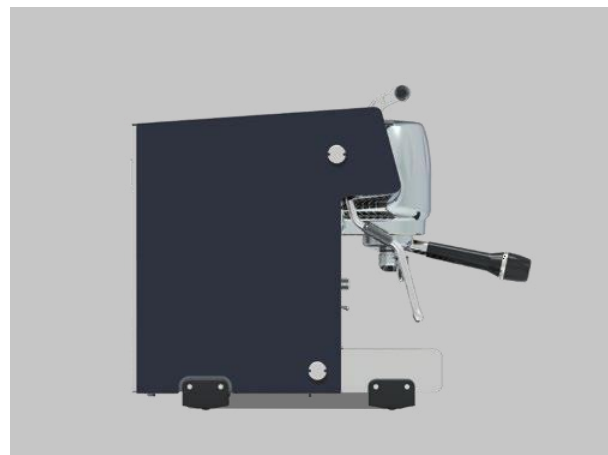

WHITE



MINT GREEN



ICE BLUE



MOON GREY

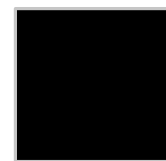

DARK



BLAZE RED



STAINLESS STEEL



NAVY BLUE

BE YOUR OWN HOME BARISTA

BE YOUR OWN HOME BARISTA Studio, Dalla Corte's professional home espresso machine, features an elegant design and high technology.

A SMALL MACHINE WITH GREAT POTENTIAL The simple display ensures that all parameters are constantly under control: set up the desired temperature and extraction time, with an intuitive and minimalistic design.

COMPACT AND ELEGANT Designed to fit even the smallest of places, Studio is the ideal choice for homes, offices, restaurants and small shops. It can be plumbed in or used by filling its water tank.

SHOW YOUR TRUE COLOURS Choose the colour that matches your style, Studio can be entirely customized in all RAL colours.

| | |
|--------------------------|----------------------|
| dimensions (w x h x d) | 321 x 390,4 x 400 mm |
| weight | 27,5 kg |
| max power | 1975 kW |
| connected load | 230/240 V 50-60 Hz |
| boiler capacity | 1,5 l |
| group head capacity | 0,5 l |
| water tank | 4 l |
| water network connection | optional |
| barista lights | included |

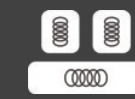

MULTIBOILER



WATER NETWORK CONNECTION (optional)



WATER TANK



BARISTA KIT



CUSTOM COLOURS



ENERGY SAVING



58mm FILTER (optional)

S+UDIO



DALLA
CORTE



S+UDIC

DALLA
CORTE

STUDIOAQUA

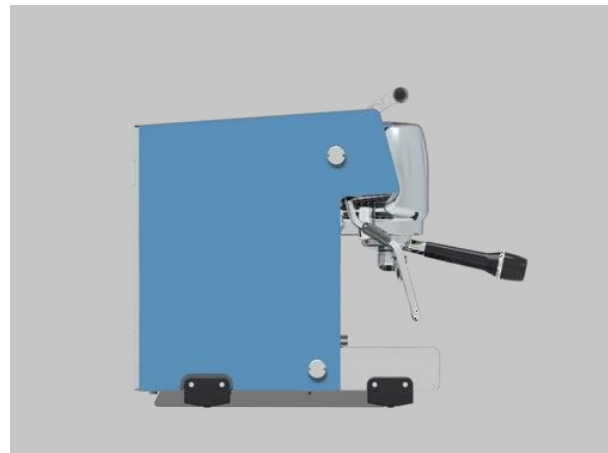

WHITE



MINT GREEN



ICE BLUE



MOON GREY

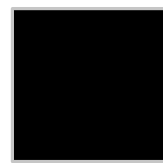

DARK



BLAZE RED



STAINLESS STEEL



NAVY BLUE

EXPAND YOUR COFFEE MENU

HOME BARISTA 2.0 Studio evolves into another version, Studio Aqua, now equipped with a hot water dispenser to expand the possibilities of the most demanding home baristas. Small size, ideal for a first-class coffee corner.

MORE RECIPES FOR YOUR HOME-CAFE' Thanks to the hot water tap, Studio Aqua meets the needs of those home baristas who want to quickly range from espresso to diluted drinks, such as a caffè Americano, or prefer to alternate their preparations with tea and infusions.

MORE THAN MEETS THE EYE Studio Aqua is also equipped with a bigger boiler for improved temperature stability. It connects to the water supply system and is equipped with a double pressure gauge for greater control.

DRIP TRAY DRAIN PLUMBED DRAIN

| | | |
|------------------------|--|--|
| dimensions (w x h x d) | 321 x 434 x 400 mm | 321 x 434 x 400 mm |
| weight | 28 kg | 28 kg |
| max power | 2770 kW | 2770 kW |
| connected load | 220/240 V 50-60 Hz, 200 V 50/60 Hz, 100/120 V 50-60 Hz | 220/240 V 50-60 Hz, 200 V 50/60 Hz, 100/120 V 50-60 Hz |
| boiler capacity | 2,5 l | 2,5 l |
| group head capacity | 0,5 l | 0,5 l |
| barista lights | included | included |

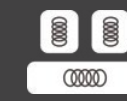

MULTI-BOILER



WATER NETWORK CONNECTION



BARISTA KIT



CUSTOM COLOURS



ENERGY SAVING



58mm FILTER (optional)

S+UDIC
aqua



EVO2



ARCTIC WHITE



NEBULA BLACK



QUARTZ GREY



SPARKLING RED



BLACKBOARD

MODERN MEETS CLASSIC

CONSISTENT EXTRACTION Patented multiboiler technology, set the temperature with a 0.1° precision and find your sweet spot.

FUNCTIONAL 54 mm-diameter portafilter, ergonomic handgrips, easy and precise milk frothing. DC System compatible (GCS, MCS, OCS).

SUSTAINABILITY Independent groups to switch off unused brewing groups or the boiler. Perfect thermal stability. All parts exposed to water are lead-free (CW510L). Made with completely recyclable materials.

BLACKBOARD EDITION Make it your own! Customize your espresso machine however you like by drawing directly on the blackboard cover - let's play, erase, and keep on creating!

| | 2 GROUPS | 3 GROUPS | 4 GROUPS |
|----------------------------|----------------|--|------------------------------------|
| dimensions (w x h x d) | 730x510x525 mm | 940x510x525 mm 940x525x525 mm | 1150x510x525 mm 1150x525x525 mm |
| weight | 67 kg | 83 kg | 100 kg |
| max power | 4,5 kW | 11,3 kW | 13,0 kW |
| boiler capacity | 7,5 l | 13 l | 13 l |
| group head capacity | 0,5 l | 0,5 l | 0,5 l |
| GCS Grinder Control System | optional | optional | optional |
| MCS Milk Control System | optional | optional | optional |
| | | 380/400 V 3 N + T, 50/60 Hz 220/230 V 3, 50/60 Hz | |

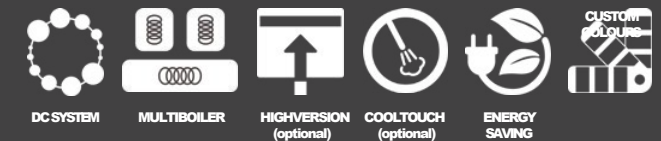

evo



DALLA CORTE

DALI CORTE

DALLA CORTE

DALLA CORTE

DALLA CORTE

DALLA CORTE

DALLA CORTE

DALLA

DALLA

DALLA

DALLA

DALLA

DALLA CORTE

ICON

ICON

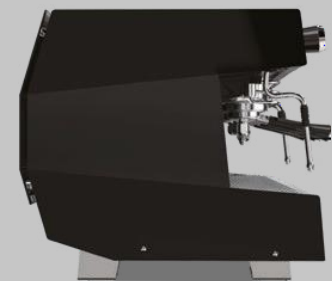

WHITE OAK



DYNAMIC WHITE



SPACE GREY



DYNAMIC BLACK



BLACK WALNUT



TOTAL MATT BLACK



DYNAMIC RED



LEATHER

IMPECCABLE PERFORMANCE

MAKE YOUR COFFEE ICONIC Icon is a reliable espresso machine that can make an excellent and consistent espresso over time, the answer to what businesses need during their busiest hours to provide impeccable results with minimum effort.

RELY ON THE DC SYSTEM The technologies of the DC system GCS, MCS and OCS, make Icon an ideal candidate for the Horeca market, where high turnover rates and frequent peak times during the day can really put quality to the test.

YOUR BRAND, YOUR ICON. Light lines and geometric cuts for the side panels formed by a single stainless-steel shell. On the back panel there's plenty of room for custom projects, thanks to a wide range of RAL colorations and special custom materials.

| | 2 GROUPS | 3 GROUPS |
|----------------------------|---|---|
| dimensions (wxhxd) | 730x510x525 mm | 940x510x525 mm |
| weight | 58 kg | 95 kg |
| max power | 4,5 kW (3,9 kW 200-220V3) | 6,3 kW (5,5 kW 200-220V3) |
| connected load | 380/400V3N +T50/60 Hz 220/230 V, 50/60 Hz 200/220 V, 3 50/60 Hz | 380/400V3N +T50/60 Hz 220/230 V, 50/60 Hz 200/220 V, 3 50/60 Hz |
| boiler capacity | 7,5 l | 13 l |
| group head capacity | 0,5 l | 0,5 l |
| GCS Grinder Control System | optional | optional |
| MCS Milk Control System | optional | optional |
| OCS Online Control System | optional | optional |



ADJUSTABLE FEET
(optional)



DOUBLE
MCS



DC SYSTEM



MULTI BOILER



COOL TOUCH
(optional)



ENERGY
SAVING



CUSTOM
COLOURS



CUSTOM
MATERIALS



58mm FILTER
(optional)

ICON

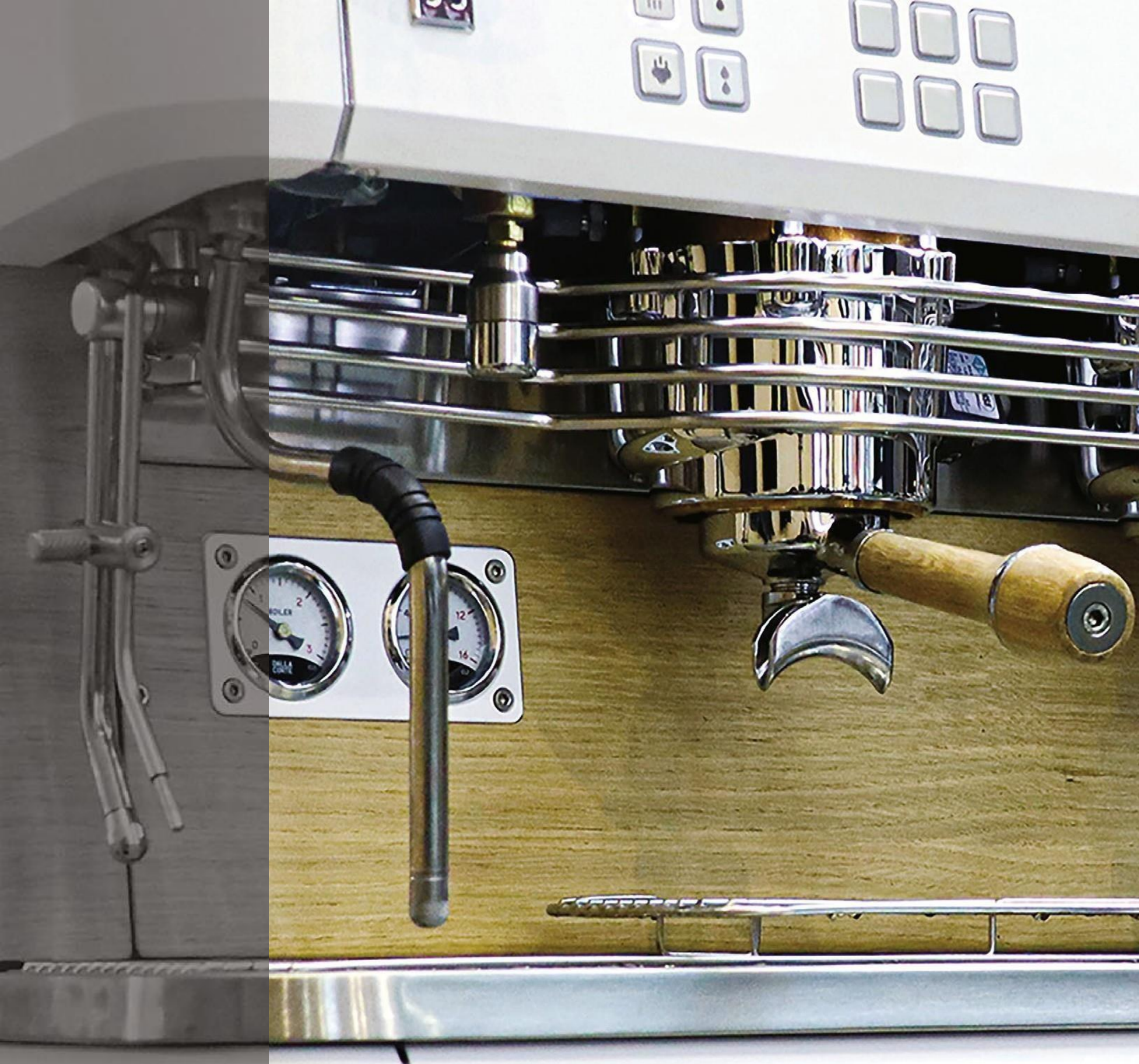

XT CLASSIC

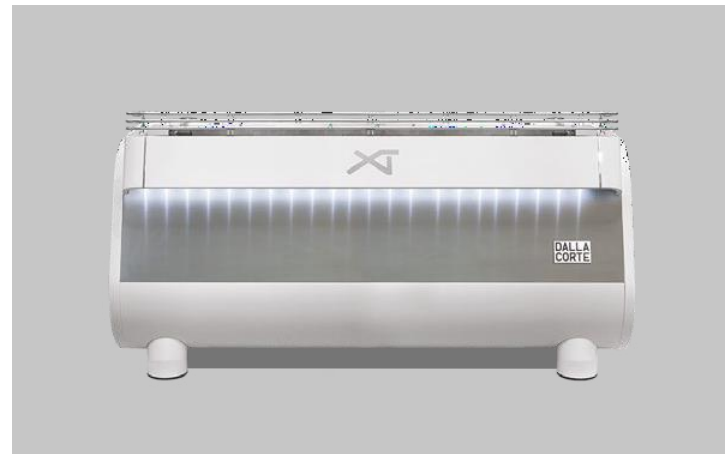

TOTAL WHITE



DYNAMIC WHITE



WHITE OAK

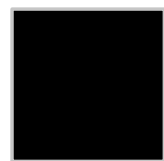

TOTAL DARK



DYNAMIC DARK



DARK WALNUT

PERFECT CONSISTENCY

SIX PRE-SET PROFILES For each group you can set up to six different recipes and save them on the six programmable buttons. Get to know your customers and always be ready to make them their favourite coffee drink.

TEMPERATURE CONTROL The original patented multiboiler technology - only the best to extract your coffee at the perfect temperature, precise down to one decimal of a degree.

ERGONOMIC DC design in every detail to guarantee maximum comfort to the barista, 54mm portafilter and optional 58mm portafilter kit: you choose the best extraction.

| | 2 GROUPS | 3 GROUPS |
|----------------------------------|---|---|
| dimensions (w x h x d) | 730x525x510 mm | 940x525x510 mm |
| weight | 74 kg | 88 kg |
| power consumption (24h-stand-by) | 7,9 kW | 11,3 kW |
| max power | 4,5 kW | 6,3 kW |
| connected load | 230/240 V 1 Ph, 200/230 V 3, 400 V 3 N | 230/240 V 1 Ph, 200/230 V 3, 400 V 3 N |
| boiler capacity | 7,5 l | 13 l |
| group head capacity | 0,5 l | 0,5 l |
| GCS Grinder Control System | optional | optional |
| MCS Milk Control System | optional | optional |





XT BARISTA



TOTAL WHITE



DYNAMIC WHITE



WHITE OAK

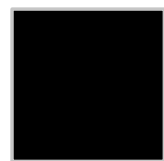

TOTAL DARK



DYNAMIC DARK



DARK WALNUT

EXTREME FLOW CONTROL

CREATIVITY XT, a name that recalls precision, consistency and creativity. Customize extraction recipes and create a unique vision of coffee, maintaining full control over the extraction.

DROP BY DROP CONTROL With the manual flow regulator you can create your own extraction profiles. Freedom from external instruments and better workflow, thanks to the Real Time Weight control.

UNIQUE, ALWAYS Create your flow, choose your portafilter, with the option of integrating a 58mm portafilter as well as a 54mm one. All the flexibility you need and your personal touch in every cup you make.

| | 2 GROUPS | 3 GROUPS |
|----------------------------------|---|---|
| dimensions (w x h x d) | 730x525x510 mm | 940x525x510 mm |
| weight | 74 kg | 88 kg |
| power consumption (24h-stand-by) | 7,9 kW | 11,3 kW |
| max power | 4,5 kW | 6,3 kW |
| connected load | 230/240 V 1 Ph, 200/230 V 3, 400 V 3 N | 230/240 V 1 Ph, 200/230 V 3, 400 V 3 N |
| boiler capacity | 7,5 l | 13 l |
| group head capacity | 0,5 l | 0,5 l |
| GCS Grinder Control System | optional | optional |
| MCS Milk Control System | optional | optional |



DC SYSTEM

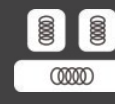

MULTIBOILER



COOL TOUCH STANDARD



FIXED FLOW



WEIGHT CONTROL



ENERGY SAVING



CUSTOM COLOURS



CUSTOM MATERIALS



58mm FILTER (optional)



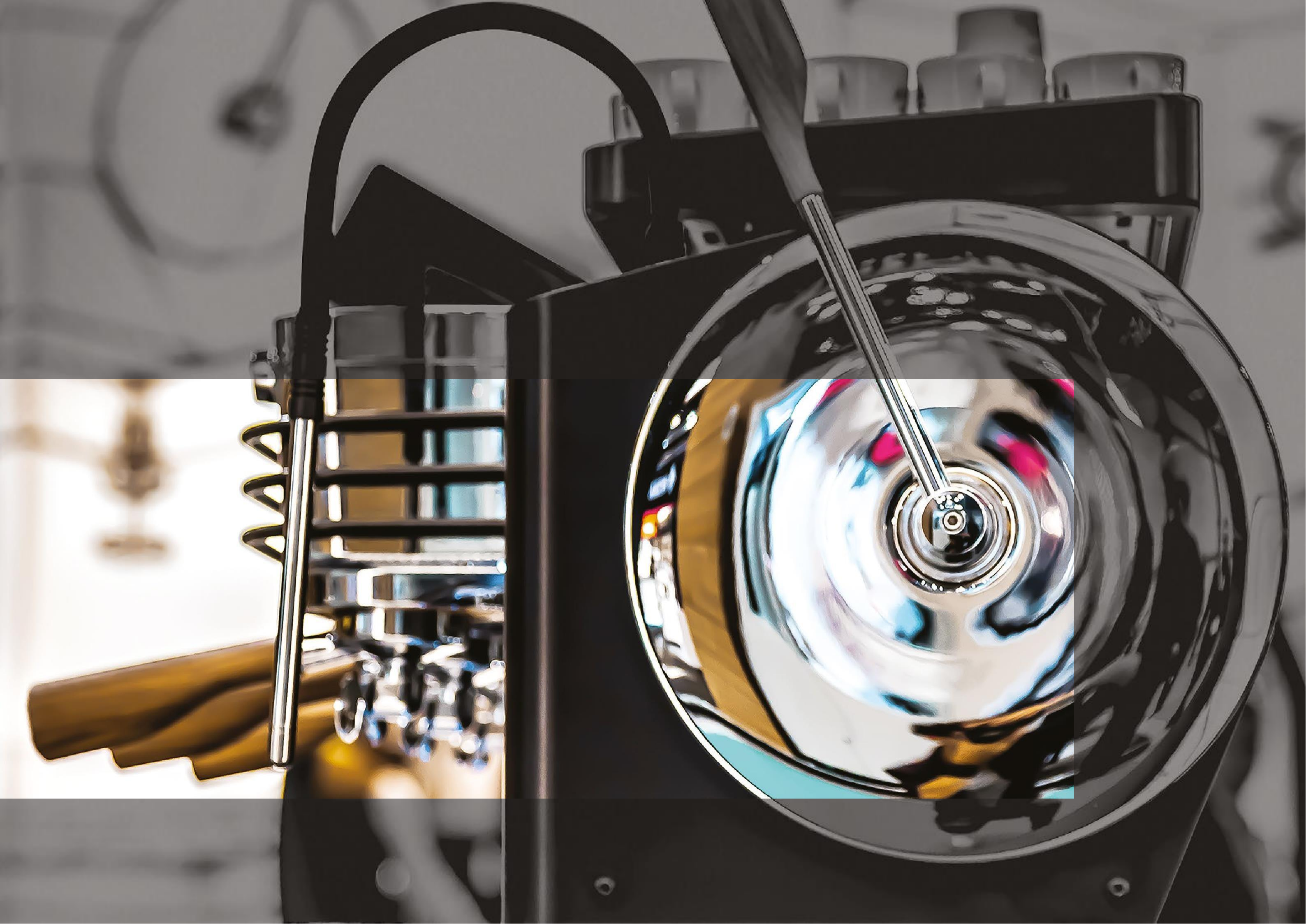

ZERO CLASSIC

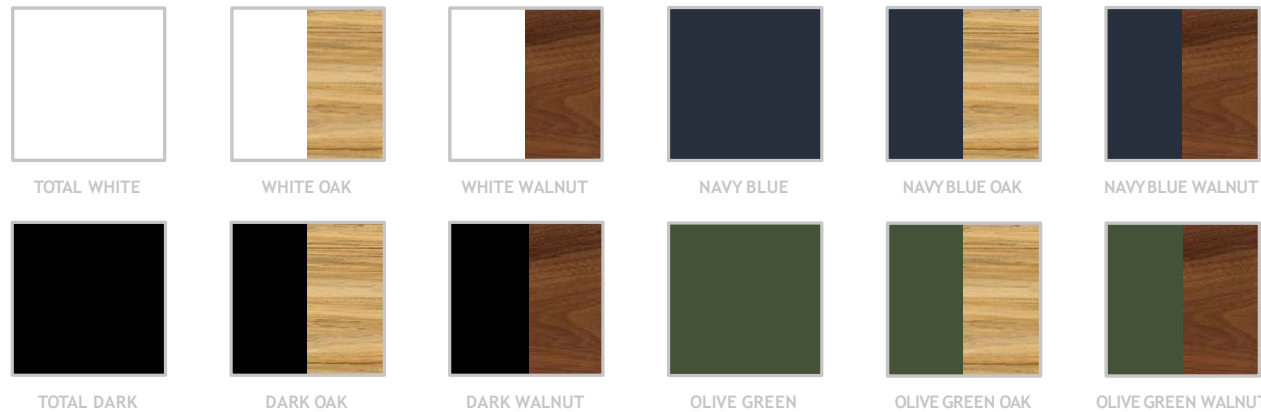

HAVE A TASTE OF OUR FUTURE VISION

THE START OF A NEW ERA For the first time since its creation in 2001, the original patented multiboiler technology has been taken to the next level with Zero's new 0.75 ltr groups. Year Zero starts now.

DIGITAL TOUCHSCREENS All functions are easily accessible with just a few touches; the most important settings are always visible on screen.

TAKE CENTRE STAGE A brand new design for the Dalla Corte Cool Touch steam wand, while still performing at the highest levels. This new version of the Cool Touch Steam Wand will be installed on all Zero Barista and Classic series. Because the best can't be optional.

| | 2 GROUPS | 3 GROUPS |
|------------------------|---|---|
| dimensions (w x h x d) | 870 x 511 x 550 mm | 1100 x 511 x 550 mm |
| weight | 85 kg | 110 kg |
| max power | 4,9 kW | 7 kW |
| connected load | 380/400 V 3 N +T, 50/60 Hz 220/230 V, 50/60 Hz | 380/400 V 3 N +T, 50/60 Hz 220/230 V, 50/60 Hz |
| boiler capacity | 7,5 l | 13 l |
| group head capacity | 2 x 0,75 l | 3 x 0,75 l |



ZERO CLASSIC

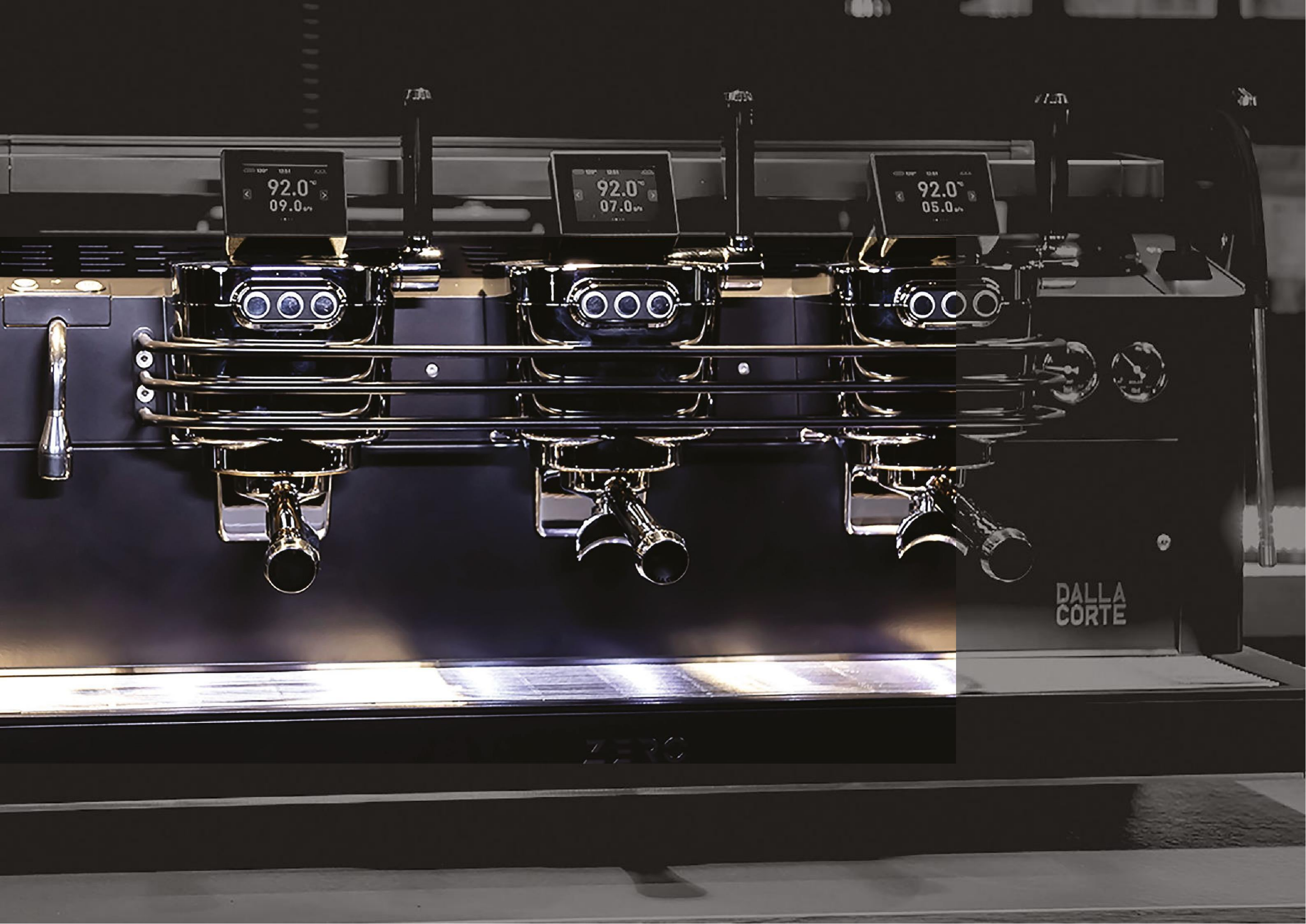

92.0°C
09.0v

92.0°C
07.0v

92.0°C
05.0v

DALLA
CORTE

ZERO

ZERO BARISTA

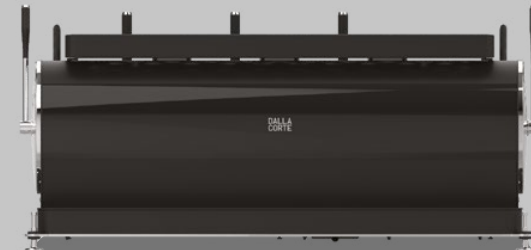
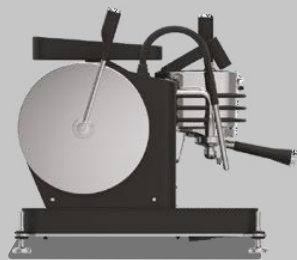

ENDLESS POSSIBILITIES ZERO LIMITS

FUTURISTIC DESIGN A machine with strong personality and an eye-catching design that highlights Dalla Corte's technological innovations and the barista's work, introducing him into a "zero limits" dimension to express himself.

FIND YOUR FLOW With the Fixed Water Flow, the flow rate is adjustable in grams per second directly on the digital touchscreens. Every single group can have a different flow rate - from 3 g/s to 9 g/s - fixed throughout the entire extraction.

FREESTYLE YOUR EXTRACTION With the Freestyle Water Flow, each lever on the side of Zero's brewing units is provided with 4 steps, each step is pre-set to a specific flow rate (3-5-7-9 g/s). Welcome to a "zero limits" dimension.

| | 2 GROUPS | 3 GROUPS |
|------------------------|---|---|
| dimensions (w x h x d) | 870 x 511 x 550 mm | 1100 x 511 x 550 mm |
| weight | 85 kg | 110 kg |
| max power | 4,9 kW | 7 kW |
| connected load | 380/400 V 3 N +T, 50/60 Hz 220/230 V, 50/60 Hz | 380/400 V 3 N +T, 50/60 Hz 220/230 V, 50/60 Hz |
| boiler capacity | 7,5 l | 13 l |
| group head capacity | 2 x 0,75 l | 3 x 0,75 l |





DC ONE

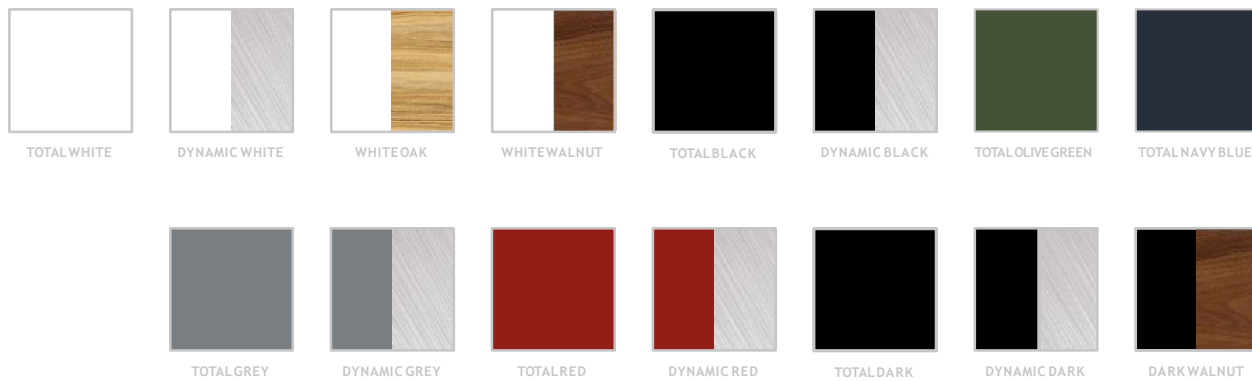

PRECISE CUT TASTY COFFEE

ON DEMAND The 65 mm flat burrs provide an extremely precise cut. Fully automatic detection of single or double shot.

CONTROL & PRECISION Exact grinding time, up to three digits after the decimal point. The automatic cooling system preserves coffee from overheating.

TEMPERATURE Grinding point with millimetric digital setting to maintain complete control over your coffee.

IT'S TIME TO CONNECT You can connect up to three grinders simultaneously to XT and one grinder to Evo2.

| | |
|------------------------|----------------------------|
| dimensions (w x h x d) | 235x570x300 mm |
| weight | 12 kg |
| grinding capacity | approx. 4 g/sec |
| hopper capacity | 1500 g |
| max power | 500 W |
| connected load | 230/240 V, 115 V |
| rotations per minute | 1350 (200 V - 50 Hz) U/min |
| grinding disc ø | 65 mm |

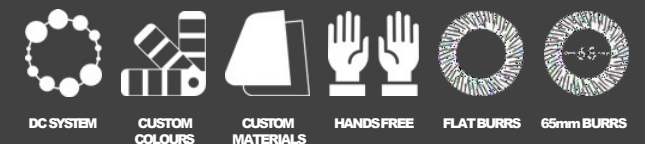



PRESS DOWN HOPPER
LOCK OPEN

PRESS DOWN HOPPER
LOCK OPEN

CC TWO

DC-TWO 30.5
◀ 5 ▶ ◀ 9 ▶
CMP CMP



DC TWO



TWICE AS MANY OPTIONS IN ONE GRINDER

PERFECT CUT Excellent extraction starts from the perfect cut. The 65 mm flat burrs, exclusively designed for espresso, provide an extremely precise cut.

SIZE, CONTROL & PRECISION Two different coffees in a compact space. Internal temperature under control at all times, thanks to a cooling fan.

GRINDING GROUP Equipped with a rotating burr holder system, which guarantees perfect parallelism between cutting parts and a uniform grind.

VERSATILE Different modes for each grinding unit: DC Two can work autonomously in Competition mode or work as part of the Grinder Control System.



| | |
|------------------------|----------------------------|
| dimensions (w x h x d) | 319x630x300 mm |
| weight | 21 kg |
| grinding capacity | approx. 4 g/sec |
| hopper capacity | 2 x 1000 g |
| max power | 800 W |
| connected load | 230/240 V, 115 V |
| rotations per minute | 1350 (200 V - 50 Hz) U/min |
| grinding disc ø | 65 mm |

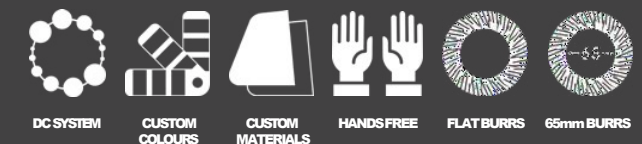
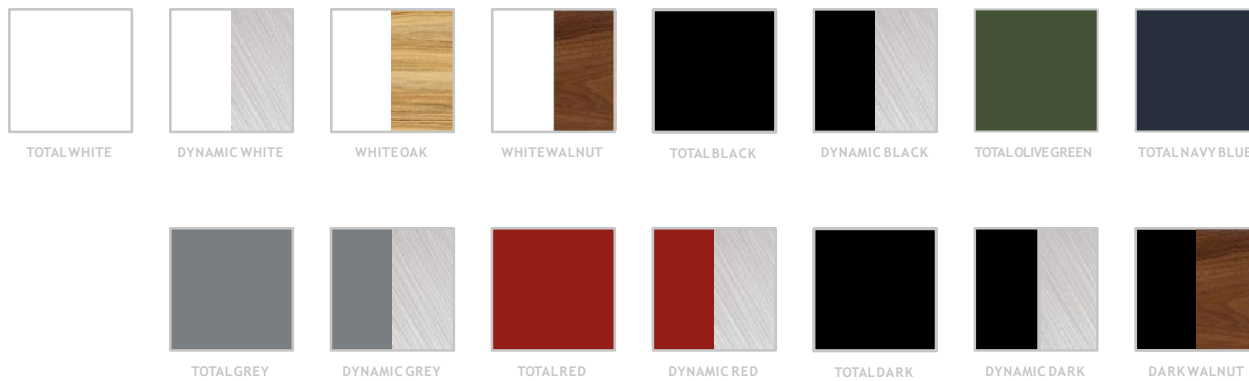



MAX



MAXIMUM POWER

COMPACT SIZE

EASY Automatic detection of single or double dose. Grind adjustment with a minimum variation of 0.01 mm.

COMPACT & USER-FRIENDLY The encoder's handgrips provide an effective grinding time adjustment and complete control over coffee. Outstanding performance in a small size.

PERFORMANCE The 65 mm flat burrs provide an extremely precise cut. The grinder can be used in both Competition and Programmed mode.

CUSTOM Customize your Max: besides its standard yellow and blackboard versions, the grinder comes in a wide range of colours and materials.

| | |
|------------------------|----------------------------|
| dimensions (w x h x d) | 160x510x250 mm |
| weight | 11 kg |
| grinding capacity | approx. 4 g/sec |
| hopper capacity | 600 g |
| max power | 500 W |
| connected load | 230/240 V, 115 V |
| rotations per minute | 1350 (200 V - 50 Hz) U/min |
| grinding disc ø | 65 mm |

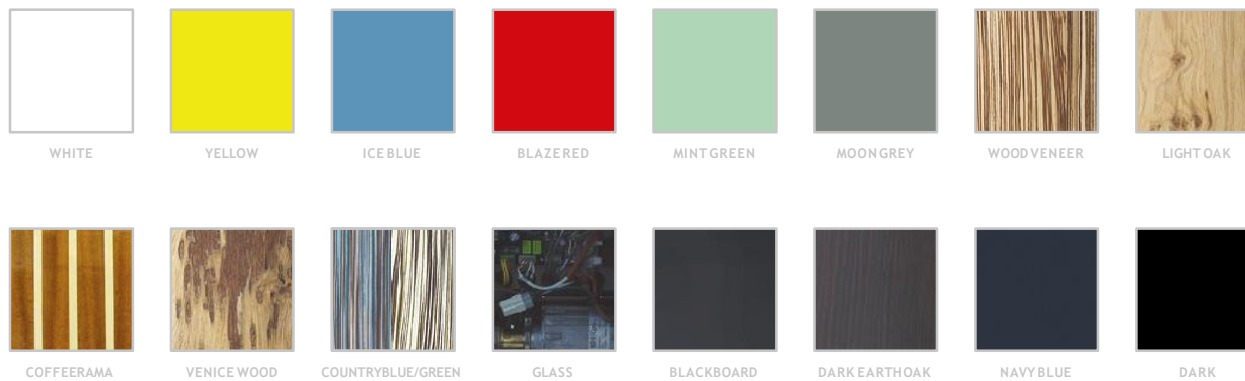

max



EDGE



BLACK

PRECISE FAST AND EASY

CUTTING-EDGE Edge grinder on-demand offers the utmost efficiency in compact dimensions, making it a perfect coffee grinder for single origins, alternative blends, and for places with limited space.

STEADY LOCK GRINDER An essential step for a good extraction is finding the perfect grind: the steady lock grinder system ensures a constant distance between the burrs, keeping the grind size setting consistent under any working condition.

CRYSTAL CLEAR Clear characters with a white on black contrast simplify the barista's work, making the selection of settings fast and easy.

| | |
|------------------------|--------------------------------|
| dimensions (w x h x d) | 164x467x251 mm |
| weight | 10 kg |
| grinding capacity | approx. 3 g/sec |
| hopper capacity | 600 g |
| max power | 400 W |
| connected load | 220/240 V, 56/60 Hz |
| rotations per minute | 1480 rpm/50 Hz, 1700 rpm/60 Hz |
| grinding disc ø | 64 mm |
| grind regulation | micrometrical stepless |
| dose setting | digital |
| user interface | touch |



edge

THIS IS HOW WE #MAKE it BETTER

MULTIBOILER

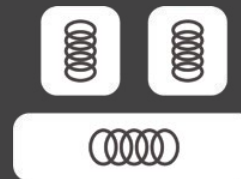

The original independent - group - technology. Every single group and the boiler work independently from one another: this allows you to switch off the groups or the boiler when you don't need them, save energy and, most of all, maintain the temperature steady for every extraction. Our first innovation, a true and proper revolution for the entire industry.

54mm PORTAFILTER



All of our machines are standardly equipped with 54mm-diameter portafilters. During coffee extraction, with the same incoming pressure, the 54mm weighs much less on the coffee puck compared to the classic 58mm. With the same amount of coffee, the 54mm ensures a taller coffee cake: hot water will take longer to flow through the coffee ground and with less pressure. The result will be a richer coffee, full-bodied and with complex aromas.

LEAD FREE



We can proudly claim that we were the first commercial espresso machines manufacturers in the world to use new, certified materials – special brass alloys that considerably improve our multigroup machines' performance and that don't release heavy metals such as nickel, chromium or lead into the water*. Now, that's a challenge!

EXTRACTION



The total amount of extraction time is given by adding pre-infusion time and percolation time. With "pre-infusion time", we describe the moment when the water enters the extraction chamber (the space between the shower and the base of the coffee cake); once this space is filled up, we'll see the first drops of coffee coming out, and the so called "percolation phase" will start.

DALLA
CORTE

DC SYSTEM



The DC System is a group of technologies thought for chains and coffee shops where there's a high staff-turnover-rate, created specifically to ensure a consistent result in the cup, for both espresso and milk-based-beverages. The DC System consists of the Grinder Control System (GCS), the Milk Control System (MCS) and the Online Control System (OCS).

GRINDER CONTROL SYSTEM - GCS



Through the GCS you can keep the grinding under control without any need for the operator to step in. By connecting DC One and DC Two to our espresso machines, the grinders will automatically change the grinding point, maintaining an ideal grind and ensuring perfect coffees. This is how we can guarantee an excellent quality at every extraction.

MILK CONTROL SYSTEM - MCS



MCS is an automatic steam wand that can guarantee perfect frothing with different types of milk. A temperature probe will automatically stop the steam when the milk reaches the optimal result that was previously set. To make the perfect cappuccino froth, fine- textured and creamy, pressing a button is all it takes.

ONLINE CONTROL SYSTEM - OCS



The OCS ensures remote control of the machine's parameters - all you need is internet access. With a smartphone, laptop or any other device, you can connect to your espresso machine and easily change the temperature of the single groups, set extraction doses, check on counters, timers, alarms and all basic parameters of your Dalla Corte. Whenever you want, wherever you like.

ENERGY SAVING



Reducing energy consumption while maintaining high performance levels? Yes, we can. The environment is our common heritage and we want to respect and preserve it. In our machines, you can use one single brewing group and turn off all the others - energy consumption is considerably lower, and so are operating costs.

FLOW



When we talk about coffee extraction, flow is the amount of water - measured in grams per second - that is dispensed in a determined span of time and pours through the coffee cake. Different varieties of coffee require different water-flows, therefore, we need to be able to operate on the pre-infusion time to extract all of the coffee's organoleptic properties into the cup.

DIGITAL FLOW REGULATION - DFR



The exclusive and patented technology that allows you to control water flow in grams per second throughout the extraction, especially during the pre-infusion phase. With Mina you can profile the flow electronically, creating your own coffee recipes. While with Zero Barista you can use the freestyle mode by using the control lever, changing the coffee's acidity, sweetness and body.

FIXED FLOW REGULATION



Fixing the water flow is ideal to extract different selections of coffee on the same espresso machine, or to enhance different characteristics from the same coffee beans. On XT Barista each group is equipped with a manual flow regulator: use the dedicated key to fix the water flow to remain constant throughout the extraction. On Zero Barista you can set the flow in g/s directly from the digital screen on top of each group instead.

MINAAPP



Through the app Dalla Corte Mina (available on App Store and Google Play), you can create new coffee profiles and save them in your personal collection. You can also operate on all the machine's parameters, enable or disable the GCS, MCS and energy-saving mode. Total control, in the palm of your hand.

WEIGHT CONTROL



On Zero and XT, you can view the weight of the coffee in the cup in real time, without any need for external scales. Through a control panel on top of each group, you can view the amount of water that was used for the whole process, and the exact weight of extracted liquid.

65mm FLAT BURRS



The 65mm flat burrs' exclusive design, specifically created for espresso, guarantees an ideal grind for any type of coffee. The one hundredth of a millimeter regulation, ensures an unprecedented precision, good coffee starts from the perfect grind.

COOL TOUCH STEAM WAND



You can have our steam wand's efficiency and a perfect milk cream without the risk of getting burnt. The double coating inside the wand prevents the external steel surface from overheating, without affecting the wand's performance.

CUSTOM VERSION



Our machines are available in different design combinations. Glass, wood, custom RAL colours, matt or shiny coating, decorated with airbrushed or laser finishes. A unique style that can suit the baristas personality or the coffeeshop's concept.

0.75 GROUP



The multiboiler has been the core technology of all Dalla Corte espresso machines since the very beginning. Over a decade later, we wanted to improve the independent group's capacity of the Zero from the original 0,5 lt to an increased 0,75 lt. Once again we #makeitbetter to meet our customers' needs.

CERTIFIED QUALITY



Used by millions of organizations around the globe, the world-standard reference for quality, ISO 9001, helps ensure that customers get good-quality products and services. Dalla Corte has certified the brand not only for the production of espresso machines and coffee grinders, but also for their installation, support, and maintenance.



DALLA
CORTE
MAKE it BETTER

MAKE it BETTER

Kelly Grayson | UK Sales Manager

Mobile +447464926627

kelly.grayson@dallacorte.com

