

USER MANUAL A300

FCS4070



Read the user manual before working on the machine.

Keep the manual with the machine and pass the manual on to the next operator if the machine is sold or transferred to a third party.



IT'S ALL ABOUT THE MOMENT

Discover more at coffee.franke.com

FRANKE

TABLE OF CONTENTS

1	For your safety	7
1.1	Intended use	7
1.1.1	Coffee machine	7
1.1.2	Add-on units	7
1.2	Prerequisites for using the coffee machine	7
1.3	Explanation of safety instructions	8
1.4	Safety concerns when using the coffee machine	8
2	Explanation of symbols	12
2.1	Symbols used in the manual	12
2.1.1	Orientation	12
2.2	Symbols used in the software	12
2.2.1	Symbols used for navigation and operation	12
2.2.2	Symbols on the dashboard and on the user interface	13
2.2.3	Depiction of error messages	15
3	Scope of delivery	16
4	Identification	18
4.1	Position of type plates	18
4.1.1	Coffee machine	18
4.1.2	SU05 cooling unit	18
4.1.3	CW (option)	18
4.1.4	AC125 CL (option)	19
4.2	Type code	19
4.2.1	Coffee machine	19
4.2.2	Add-on units	19
5	Description of machine	21
5.1	Coffee machine	21
5.1.1	Standard	21
5.1.2	Options	21
5.1.3	Versions	22
5.2	Add-on units	22
5.2.1	Parts of the cooling unit	22
5.2.2	Cup warmer	23
5.2.3	Accounting system	23
5.3	Overview of operating modes	24
5.3.1	User interface	24
5.3.2	Quick Select operating mode	24
5.3.3	Operating modes in combination with Credit Mode	24
5.4	Franke Digital Services (option)	25
6	Installation	26
6.1	Preparations	26
6.2	Dimensions	26
6.2.1	Feet	28
6.3	Requirements of the water supply	28

6.3.1	Main water connection	28
6.3.2	Determining the water hardness with a measuring strip	28
6.3.3	Water quality	29
6.3.4	Water outlet	30
6.4	Setting up and preparing the coffee machine	30
6.5	Connect the water supply	30
6.6	Connecting the wastewater	31
6.7	Connecting electrical circuit	31
6.8	Switching the machine on	32
7	Switching on the machine for the first time	33
7.1	Fill resources	34
7.2	Inserting a descaling cartridge	34
8	Filling and emptying	36
8.1	filling the machine	36
8.2	Filling beans	36
8.3	Using and storing roasted coffee beans	37
8.4	Filling powder	37
8.5	Filling the water tank	38
8.6	Filling the cooling unit	38
8.6.1	SU05 cooling unit	39
8.7	Setting the grind coarseness	40
8.8	Emptying the powder hopper	40
8.9	Emptying the grounds container	41
8.10	Empty the drip tray	42
8.11	Emptying the cooling unit	43
8.11.1	SU05 cooling unit	43
9	Preparing beverages	45
9.1	Preparing beverages with Quick Select	45
9.2	Preparing beverages with Cash Register	45
9.3	Preparing hot water	46
9.4	Steam output	47
9.4.1	Purging the steam wand after use	47
10	Cleaning	48
10.1	Introduction	48
10.2	Required cleaning accessories	48
10.3	5-step method	48
10.4	Starting the cleaning process	49
10.4.1	Starting cleaning via the Cleaning and Maintenance menu	49
10.5	Loosen bean hopper finger guard for cleaning	49
10.6	Cleaning the aerator	50
10.7	Weekly cleaning	50

10.7.1	Cleaning the machine surface	50
10.7.2	Cleaning the water tank (if present)	50
10.7.3	Cleaning the powder hopper	51
10.7.4	Cleaning the drip tray and drip grid.	51
10.7.5	Cleaning the screen	52
10.8	Rinsing the coffee machine	53
10.9	Care kit	53
10.9.1	Replacing the brewing unit	55
11	Descaling	56
11.1	Descaling due date	56
11.2	Descaling	56
11.2.1	Descaling after cleaning	56
11.2.2	Descaling independent of cleaning	57
11.2.3	Initiating descaling manually	57
12	Configuration	58
12.1	Calling up the maintenance level	58
12.2	PIN codes	58
12.3	Input methods	58
12.4	My settings	59
12.4.1	Setting beverages	59
12.4.2	Set resources	60
12.4.3	Set machine	62
12.4.4	Access rights	64
13	Individualization and data transfer	65
13.1	Overview	65
13.2	Multimedia functions	65
13.3	Manage Digital Signage via USB stick	65
13.4	Configure application	66
13.4.1	Language settings	66
13.4.2	Operating mode	67
13.4.3	Display [Operating mode]	67
13.4.4	Nutritional value settings	67
13.4.5	Accounting	67
13.4.6	Transaction approval (API)	68
13.5	Loading/backing up data	68
13.5.1	Back up data	68
13.5.2	Load data	68
13.5.3	Back up XML data	69
13.6	Set default values	69
13.7	Activating configurations	69
14	Troubleshooting	70
14.1	Error messages	70
14.1.1	Color code for error messages	71
14.2	Troubleshooting the system	71
14.2.1	Restarting the machine	72

14.3	Tips for good coffee beverages	73
14.4	Help with problems concerning product quality	73
15	Decommissioning	75
15.1	Preparing for decommissioning	75
15.2	Back up data	75
15.3	Short-term decommissioning (up to 3 weeks)	75
15.4	Long-term decommissioning	76
15.5	Transport and storage	76
15.6	Recommissioning after prolonged periods of storage or non-use	76
16	Disposal of parts	77
17	Technical data	78
17.1	Capacities in accordance with DIN 18873-2:2016-02	78
17.2	Electrical connection data	78
		79

1 FOR YOUR SAFETY

1.1 Intended use

1.1.1 Coffee machine

- The A300 is a commercial machine for preparing beverages and is intended for use in food services, offices and other similar environments.
- The A300 is designed to process whole coffee beans, chocolate powder that is suitable for automatic devices, and fresh milk.
- The A300 is designed to process whole coffee beans, chocolate powder that is suitable for automatic devices, and fresh milk.
- The A300 is intended for the preparation of beverages in accordance with these instructions and the technical data.
- The A300 is intended for operation indoors.

Please note

- The A300 is not suitable for use outdoors.

1.1.2 Add-on units

Cooling unit

- The cooling unit is intended exclusively to keep milk cool for the preparation of coffee drinks with a Franke coffee machine.
- Only use precooled milk (2-5 °C).
- Remove the milk when the cooling unit is not in use. Store the milk in a suitable refrigerator.
- Use only the recommended cleaners. Other cleaners may leave residues in the milk system.
- The cooling unit is intended exclusively for operation indoors.
- Please also observe the Declaration of Conformity delivered with the device.

Cup warmer

- The cup warmer is intended only for preheating coffee cups and glasses used when preparing drinks.

Please note

- Drinking containers made of paper or plastic must not be used. The cup warmer is not designed to dry dish towels or other cloths. It is not necessary to cover the cups to warm them.

Accounting system

- Depending on the version, the accounting system can be used for various methods of payment. Examples: Payment with coins, cards, or mobile payment systems.

1.2 Prerequisites for using the coffee machine

- The A300 is intended for use by trained personnel or as a self-service machine.
- Self-service machines must always be monitored to protect the users.

- Each operator of the A300 must have read and understood the manual. This does not apply to its use in the self-service area.
- Do not operate the A300 or add-on units until you have completely read and understood this manual.
- Do not use the A300 or add-on units if you are not familiar with the various functions.
- Do not use the A300 if the connection lines of the A300 or the add-on units are damaged.
- Do not use the A300 unless the A300 or the add-on units have been cleaned or filled as intended.
- Children under the age of 8 are not permitted to use the A300 and the add-on units.
- Children or persons with restricted physical, sensory or mental abilities, or lack of experience and knowledge, may only use the A300 and the add-on units under supervision or after adequate instruction by a person responsible for their safety; they are not permitted to play with the A300 and the add-on units.
- Children are not permitted to clean the A300 and the add-on units.

1.3 Explanation of safety instructions

To ensure personal safety and the protection of material goods, observation of these safety instructions is imperative.

Symbol and signal word indicate the severity of the hazard.



WARNING

WARNING indicates a potential danger. **DANGER** indicates an imminent danger which, if not avoided, will result in death or serious injury.



CAUTION

CAUTION indicates a hazardous situation which, if not avoided, could result in minor or moderate injury.



NOTICE

NOTICE directs your attention to the risk of damage to machinery.

1.4 Safety concerns when using the coffee machine



WARNING

Risk of fire

If the power cord is electrically overloaded, the heat generated can cause a fire.

- a) Never use power outlet strips, multi-sockets or extension cords to connect the coffee machine to the power supply.

**WARNING****Risk of fatal injury from electrocution**

Damaged power cords, pipes or plugs can lead to electrocution.

- a) Do not connect any damaged power cords, pipes or plugs to the power grid.
- b) Replace damaged power cords, pipes or plugs.
If the power cord is permanently assembled, contact the service technician. If the power cord is not permanently assembled, order and use a new, original power cord.
- c) Ensure that the machine/appliance and the power cord are not near any hot surfaces such as gas or electric stoves or ovens.
- d) Ensure that the power cord is not pinched and does not chafe on sharp edges.
- e) Only pull on the plug and not on the cable when disconnecting the device from the power grid.

**WARNING****Risk of fatal injury from electrocution**

Liquid/moisture entering the machine or leaks can lead to electrocution.

- a) Never point a liquid or steam jet at the machine.
- b) Do not pour any liquids on the machine.
- c) Do not immerse the machine in liquid.
- d) Disconnect the machine from the power supply in the event of a leak or if liquid/moisture enters the machine.

**WARNING****Risk of fatal injury from electrocution**

Work, repairs or servicing improperly performed on electrical systems can lead to electrocution.

- a) Have repairs on electrical parts carried out by service technicians using original spare parts.
- b) Have servicing carried out by authorized persons with corresponding qualification only.

**WARNING****Danger of suffocation**

Plastic packaging materials could cause children to suffocate.

- a) Ensure that children have no access to plastic packaging materials.

**WARNING****Risk of scalding**

Hot water is released during rinsing.

- a) Keep hands away from the spouts and nozzles during this process.
- b) Do not place anything on the drip grid.
- c) IN CASE OF SCALDING: Immediately cool the affected area and, depending on the severity of the injury, consult a doctor.

**WARNING****Risk of scalding**

Hot beverages can lead to scalding.

- a) Always be careful with hot beverages.
- b) Use only suitable drinking vessels.

**WARNING****Risk of scalding**

Hot liquids and steam escape during cleaning and can lead to scalding.

- a) Keep hands away from the spouts and nozzles during this process.

**WARNING****Risk of injury**

If objects find their way into the bean hopper or grinder, splinters may be ejected, leading to injury.

- a) Never insert any objects into the bean hopper or grinder.

**CAUTION****Cutting injuries/crushing**

The powder hoppers worm gear mechanism can cause cuts or crushing injuries.

- a) Exercise care when cleaning the powder hopper.

**CAUTION****Irritation from cleaners**

Cleaning tablets, milk system cleaning agent, and descaler can lead to irritation of the skin or eyes.

- a) Observe the hazard warnings on the label of the respective cleaner.
- b) Avoid contact with your eyes and skin.
- c) Wash your hands after coming into contact with cleaning supplies.
- d) Cleaning supplies must be kept away from beverages.

**CAUTION****Health hazard due to germ formation**

Inadequate cleaning can result in food residues accumulating in the machine and at the spouts, thereby contaminating products.

- a) Do not use the machine unless it has been cleaned according to the instructions.
- b) Clean the machine daily in accordance with the instructions.
- c) Inform operating personnel of the necessary cleaning measures.

**CAUTION****Health hazard due to germ formation**

Residues may build up in the machine if not used for a long time.

- a) Clean the machine if it is not used for extended periods (more than 2 days).

**CAUTION****Formation of mold**

Mold can form on the coffee grounds.

- a) Empty and clean the grounds container at least once a day.

**NOTICE****Machine damage caused by limescale build-up**

If the water hardness is set incorrectly, limescale can build up in the coffee machine. Limescale deposits may damage the coffee machine.

- a) Measure the water hardness during commissioning. Then set the water hardness in the Commissioning menu on the basis of the measurement. Determining water hardness using measuring strips













To descale the machine, only use the descaler concentrate from Franke (item number 560.0589.837). This guarantees reliable descaling results.

- a) Make sure that you order descaler concentrate in good time so that you can descale the coffee machine immediately when the prompt appears on the coffee machine operator panel.

2 EXPLANATION OF SYMBOLS

2.1 Symbols used in the manual



2.1.1 Orientation

Symbol	Description
	Clean components using the 5-step method.
	This symbol indicates tips, tricks and additional information
	Prerequisites for additional steps
	Finely ground
	Coarsely ground
	Information to optimize the quality of the beverages
	Result or intermediate result for additional steps
	Bean hopper
	Powder hopper
	Filling the water tank
	Empty the grounds container

2.2 Symbols used in the software

2.2.1 Symbols used for navigation and operation













Symbol	Designation	Description
	Cancel button	Cancel preparation

















Symbol	Designation	Description
	Select next/previous page	Scroll through menus with multiple pages
	Start button	Start preparation

2.2.2 Symbols on the dashboard and on the user interface



If an error occurs, a symbol that represents the affected component will light up on the dashboard. For more information, see the *Troubleshooting [70]* chapter.

Symbol	Designation	Description
	Franke logo	Call up the maintenance level
	Ground coffee	
	Energy-saving mode	Switch the machine into energy-saving mode
	Servicing/cleaning	Machine must be cleaned and/or serviced
	Rinse	Machine must be rinsed or machine is rinsing
	Descaling	Descaling the coffee machine
	Water filter	
	Grounds container	Grounds container must be emptied
	Drip tray	Drip tray is full or not installed correctly
	Door	The door is open
	Water tank	Water tank is empty or missing
	Payment	Payment active
	Service/configuration/administration	

Symbol	Designation	Description
	Beverage settings	
	Language	Set language
	Edit	Edit settings
	Individualization	Customize beverages and display
	Advertising images	
	Set machine	
	Product	
	Access rights	Manage user permissions
	Coffee bean	Bean hopper is empty or not installed correctly
	Milk	Milk container is empty or not installed correctly
	Powder resource	Powder hopper is empty or not installed correctly
	Resource settings	Set resources
	System information	
	Counter	
	Individual products counter	
	Inactive	
	Data transfer	Data is being transferred

2.2.3 Depiction of error messages



Highlighted products cannot be prepared. The illuminated symbol on the dashboard takes you to the error message.

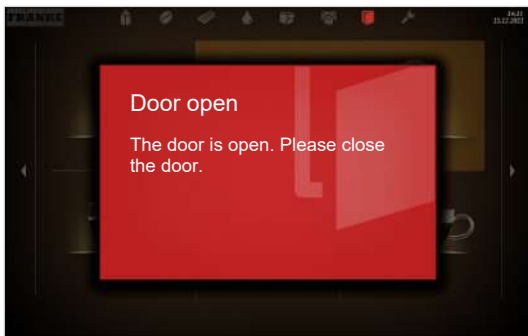

If the entire system is affected by an error, the error message will appear automatically.













Color code for error messages



-
- Temporary interruption
-
- System still fully functional
-
- System has limited functionality
-
- Some or all resources are locked
-

3 SCOPE OF DELIVERY



The scope of delivery may vary, depending on the configuration of the appliance. Additional accessories may be obtained directly from your retailer or from Franke Kaffeemaschinen AG in Aarburg, Switzerland.

	Item description	Item number
	Coffee machine A300 (FCS4070)	
	Manual set	560.0595.403 / 560.0595.410
	Descaler concentrate	560.0589.837
	Cleaning tablets (100 pcs.)	567.0000.010
	Cleaning tablets (China)	567.0000.016
	Cleaning tablets (USA/Canada)	567.0000.002
	Milk system cleaning agent (dosing bottle)	567.0000.005
	Milk system cleaning agent (dosing bottle) (USA/ Canada/Mexico)	567.0000.006
	Water hardness test strip	560.0004.060
	Cleaning brushes	560.0003.728
	Twisted-in-wire brush (Option SU05)	560.0001.019
	Hose brush (option FM/MS)	560.0007.380
	Paint brush	560.0003.716
	Microfiber cloth	560.0002.315

	Item description	Item number
	Collecting container	560.0612.966
	Single milk spout See enclosed mounting instructions	560.0613.850
	Measuring cup	560.0597.258

4 IDENTIFICATION

4.1 Position of type plates

4.1.1 Coffee machine

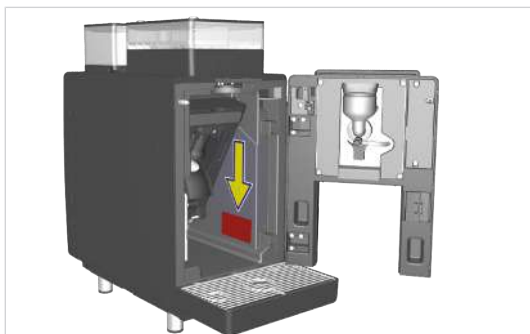

The type plate for the coffee machine is located on the right interior wall.

4.1.2 SU05 cooling unit



The type plate for the SU05 cooling unit is located on the left inner wall.

4.1.3 CW (option)



The type plate for the cup warmer is located in the interior on the rear panel.

4.1.4 AC125 CL (option)

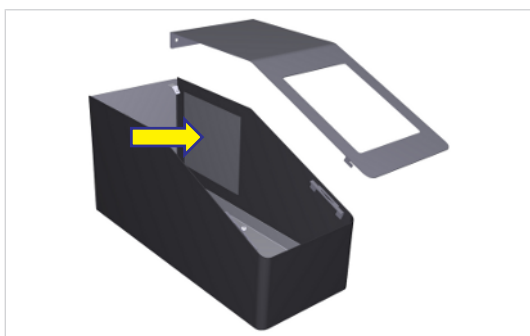

The type plate of the AC125 CL is located on the right-hand inner side.

4.2 Type code

4.2.1 Coffee machine

Type code	Description
A300	Coffee machine (fully automatic) Series: A Overall size: 300
1G	1 grinder
2G	2 grinders
1P	1 powder dosing unit
2P	2 powder dosing units
EC	EasyClean
H1	Left-hand hot water spout
FM	FoamMaster (cold and warm milk, cold and warm milk foam)
MS	MilkSystem
NM	NoMilk (coffee machine without milk system)
S1	Steam wand
W3	Internal water tank
W4	Main water connection

4.2.2 Add-on units

Type code	Description
SU03	Cooling unit (3 l) positioned next to the coffee machine
SU05	Cooling unit (5 l) positioned next to the coffee machine
KE200	Cooling unit (4 l) positioned next to the coffee machine
CW	Cup warmer
FM	FoamMaster (cold and warm milk, cold and warm milk foam)
EC	EasyClean
MS	MilkSystem
AC	Accounting system

Type code	Description
CL	Cashless

5 DESCRIPTION OF MACHINE

5.1 Coffee machine

The A300 coffee machine is available with numerous options. Please note that your coffee machine may look different from the configuration shown here.

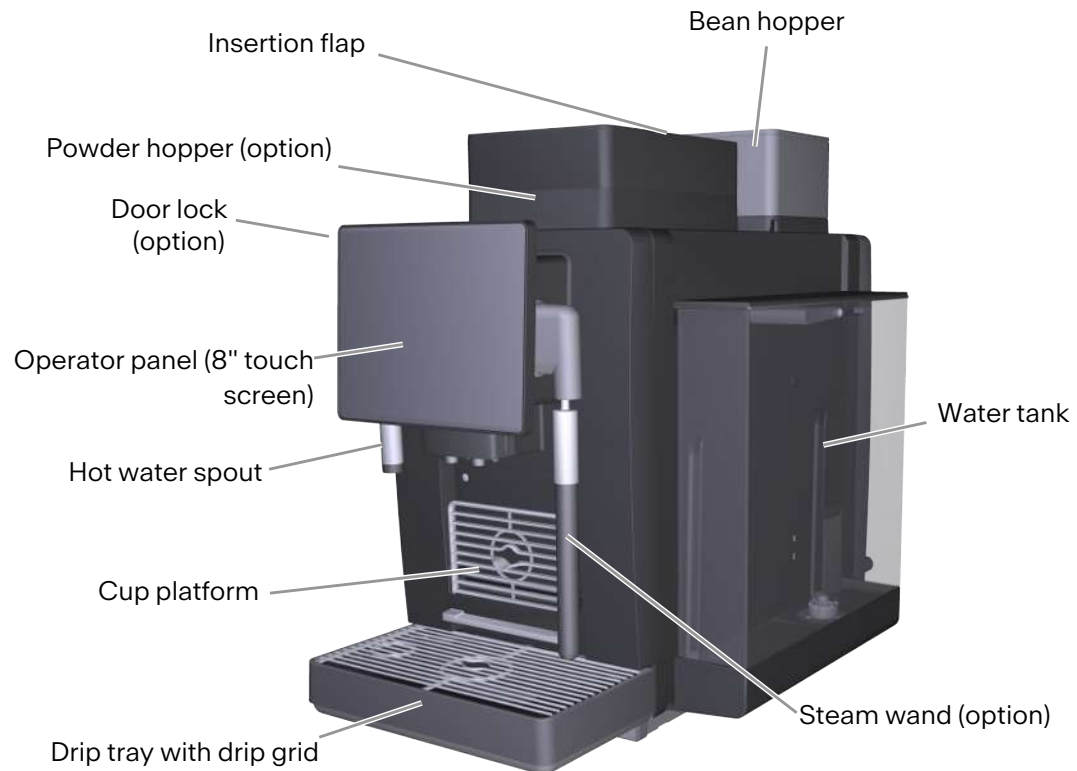

5.1.1 Standard

- 8" touch screen
- One grinder (rear LH)
- Hot water spout
- Main water connection or water tank
- Automatic descaling system

5.1.2 Options

- Additional unit for bean hopper
- Single powder dosing unit
- Twin powder dosing unit
- Steam wand S1 (only with MS EC)
- Grounds ejection (only in conjunction with main water connection)
- Door lock
- Lockable bean and powder hopper

- Lockable bean hoppers
- Feet, 40 mm
- Adjustable feet, 70 mm
- Adjustable feet, 100 mm
- Franke Digital Services

5.1.3 Versions

Water supply	Product type
A300 with main water connection	A300 NM
	A300 MS EC
	A300 FM EC
A300 with water tank	A300 NM
	A300 MS EC
	A300 FM EC

5.2 Add-on units

5.2.1 Parts of the cooling unit

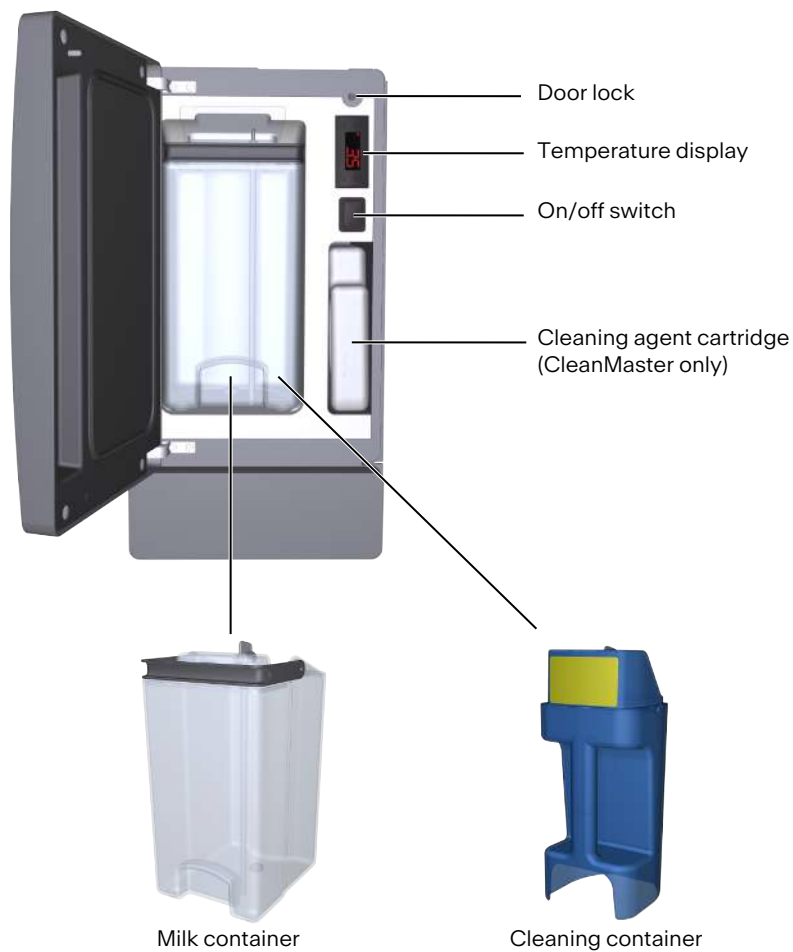

SU05



SU03

5.2.2 Cup warmer

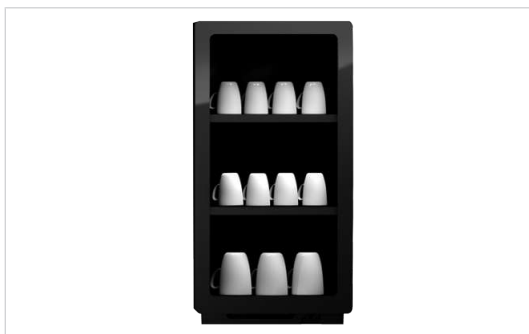

To enjoy coffee at its best, you need pre-heated cups. The cup warmer with four heatable shelves fits perfectly to your coffee machine.

5.2.3 Accounting system



The accounting system processes all payment transactions and records all accounting data.

Interfaces:

- VIP

Payment systems:

- Card readers

5.3 Overview of operating modes



The suitable operating mode depends on the utilization of your coffee machine, your product range and the preferences of your customers.

Your service technician will be happy to help you set the appropriate operating mode.

5.3.1 User interface

5.3.2 Quick Select operating mode



The Quick Select operating mode is the standard setting for self-service. Once your customer has selected a beverage, he/she can adapt it in the second step if product options are activated.

Structure of the user interface

- Level 1: Product selection, up to 5 pages; 6, 12 or 20 product buttons can be displayed per page
- Level 2: Customize beverages, select product options, initiate beverages preparation process

Individual adaptations

- Display: 2x3, 3x4 or 4x5 products per page
- Individual arrangement of beverages

5.3.3 Operating modes in combination with Credit Mode



The Credit Mode works with every operating mode and makes the product prices, credit and lack of credit clear on the operator panel.



In the Drink Selection status, you cannot add any drink options with the Credit Mode configuration. You can activate the Credit Mode in the My settings menu under 1 Set machine > 1.12 Payment. Select Activate payment.



Display

- Product prices
- Credit
- Missing credit

Menu item 1.12 Payment

5.4 Franke Digital Services (option)

Developed specially for the Franke coffee machine fleet, our digital services give you control and a clear overview of all activities and information about the coffee machines. Centrally controlled remote maintenance, such as software and configuration updates, means that on-site interventions are not required.

You can obtain additional information from your Franke service technician or on the Franke website.

6 INSTALLATION

6.1 Preparations

- The main power connection for the coffee machine must be protected by a residual current circuit-breaker (RCCB).
- Each terminal of the power supply must be able to be interrupted using a switch.
- The water connection must comply with *Requirements of the water supply [28]* and local and national rules and regulations.
- The coffee machine must be connected to the water supply with the supplied hose kit. Do not use any other water hoses that happen to be present.
- Make sure that the coffee machine can be placed on a horizontal and stable support. The operator panel should be at eye level and allow ergonomic operation.



You must have completed these preparations before a service technician can install the coffee machine for you. The service technician will install your coffee machine and carry out the initial commissioning process. The technician will walk you through the basic functions.

6.2 Dimensions



All dimensions are specified in mm.

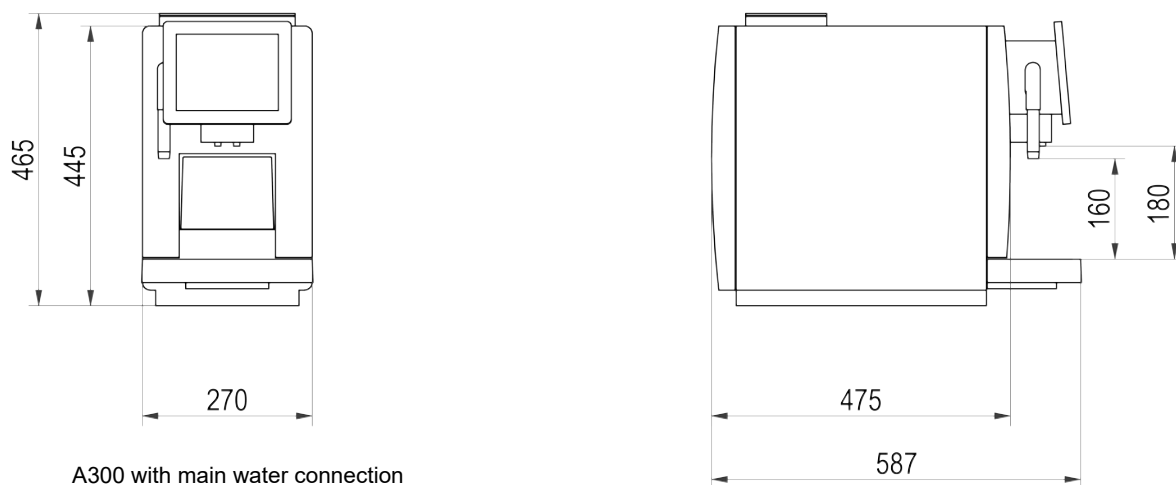

A300 with main water connection

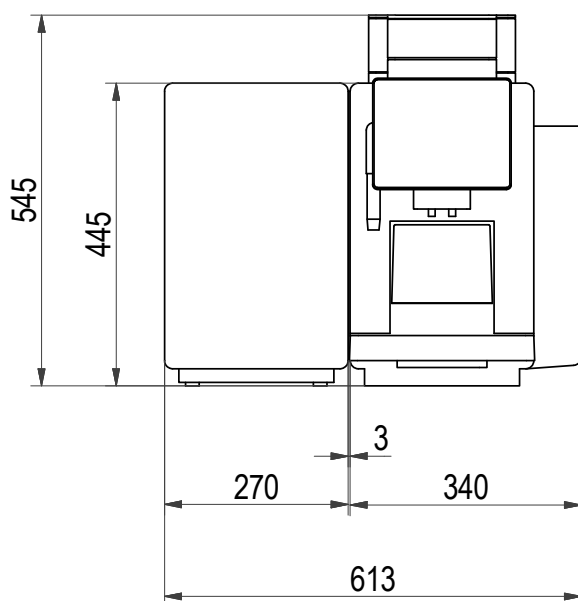

A300 with water tank and SU05

Minimum clearances

- To the rear panel: 50 mm
- Above: 200 mm (for filling and removal of the bean hopper)
- To the right: 100 mm (for opening the door)



NOTICE

Overheating damage

If the clearances around and above the machine are too small, heat may accumulate in the machine and lead to faults.

- a) Maintain the prescribed installation dimensions and clearances.
- b) Take care to ensure that the clearance spaces are not blocked.

6.2.1 Feet

A300 is delivered with feet.

- Feet 40 mm (standard)
- Feet 7 mm (option)
- Feet 70 mm (option)
- Feet 100 mm (option)

Adjustable feet can be used to compensate for unevenness or differences in height.

6.3 Requirements of the water supply

6.3.1 Main water connection

Water pressure	0,8-8,0 bar
Flow rate	>100 ml/s
Water temperature	<25 °C
Connection to the main water connection	G3/8" compression fitting and metal hose l = 1500 mm
	Only connect with the hose kit provided

- The main water connection must meet the requirements of the technical data and comply with applicable federal, state, and local regulations.
- The main water connection must have a backflow prevention device.
- The main water connection must be equipped with a shut-off valve and a check valve with an upstream filter accessible for inspection. It must be possible for the filter to be removed for cleaning.
- Water from the household decalcification system must not be used.
- Filter with at least 100 loops/inch (UL)

6.3.2 Determining the water hardness with a measuring strip



NOTICE

Machine damage caused by limescale build-up

If the water hardness setting is incorrect, limescale can build up in the coffee machine. Limescale deposits may damage the coffee machine.

- a) Measure the water hardness during commissioning. Then set the water hardness in the Commissioning menu on the basis of the measurement.

The hardness level of the water in use determines the capacity of the water filter (only in conjunction with mains water connection) and the amount of water in between descaling cycles. Once the hardness level has been set in the machine program, the coffee machine will automatically prompt you to descale the machine at the correct time.

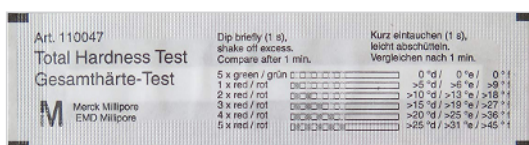

Packaged water hardness measuring strip

1. Remove the measuring strip from the packaging.

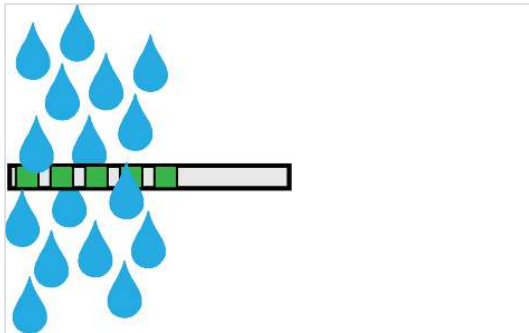

2. Dip the measuring strip into the water for 1 second.

3. Gently shake off any excess water.



⇒ The color of the measuring strip will change.

4. After one minute, read off the water hardness level. The water hardness corresponds to the number of red-colored fields.
5. Enter the measured result into the maintenance menu of the machine under **Water settings** [63].

Conversion table; Descaling prompts for machines without water filter

Hardness level	Result shown on the measuring strip	Water hardness	Descaling prompt after	Mandatory descaling after
0	0 x red	>0° dH/>0°e/>0°fH	12 operating days	14 operating days
1	1 x red	>5° dH/>6°e/>9°fH	100 l	125 l
2	2 x red	>10° dH/>13°e/>18°fH	80 l	100 l
3	3 x red	>15° dH/>19°e/>27°fH	60 l	75 l
4	4 x red	>20° dH/>25°e/>36°fH	40 l	50 l
5	5 x red	>25° dH/>31°e/>45°fH	20 l	25 l

6.3.3 Water quality

Total hardness:	4–8° dH GH (German total hardness) 7–14° fH GH (French total hardness) 4,2–8,3 GPG 70–140 ppm (mg/l)
Carbonate hardness	3–6° dH KH / 50–105 ppm (mg/l)
Acid content/pH value	6.5–7.5 pH
Chlorine content	< 0.5 mg/l
Chloride content	< 30 mg/l
TDS (total desolved solids)	30–150 ppm (mg/l)
Electrical conductivity (measured)	50–200 µS/cm (microsiemens)
Iron content	< 0.3 mg/l

- Color: Clear
- Taste: Fresh and pure taste
- Aroma: No perceptible aroma
- No rust particles in the water

6.3.4 Water outlet

- Drain hose: D = 20 mm, L = 2000 mm
- Connection to a lower-lying siphon

6.4 Setting up and preparing the coffee machine

Unpack and check scope of delivery

1. Check packaging for transport damage.
2. Unpack appliances.
3. Check that delivery is complete (see Scope of delivery and order).



NOTICE

Overheating damage

If the clearances around and above the machine are too small, heat may accumulate in the machine and lead to faults.

- a) Maintain the prescribed installation dimensions and clearances.
- b) Take care to ensure that the clearance spaces are not blocked.

6.5 Connect the water supply



NOTICE

Water damage

If the mains water connection is not implemented correctly, this may result in water damage. The operating company is responsible for ensuring that the mains water connection is implemented correctly.

- a) Take into account the data listed regarding Water connection.
- b) Check that there are no leaks in the mains water connection.



Open-end wrench 19 mm

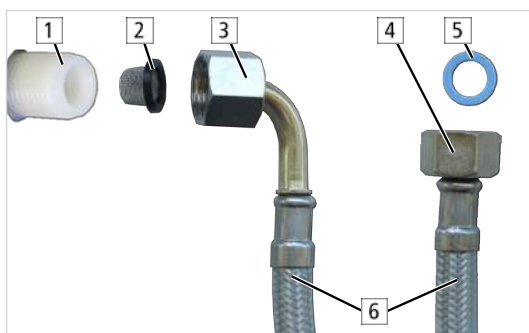

1	Coffee machine	2	Strainer with seal
3	Coffee machine fitting	4	Water system fitting
5	Seal	6	Water hose

1. Rinse the water hose and the water supply line thoroughly to remove any dirt or debris.
2. Connect the water hose with the strainer to the coffee machine.

3. Connect the water hose with the seal to the water system.
4. Fasten the screw joints hand-tight.



5. Open the water supply.
6. Check the mains water connection for absence of leaks.

6.6 Connecting the wastewater

- ✓ The components for securing the wastewater hose are present.

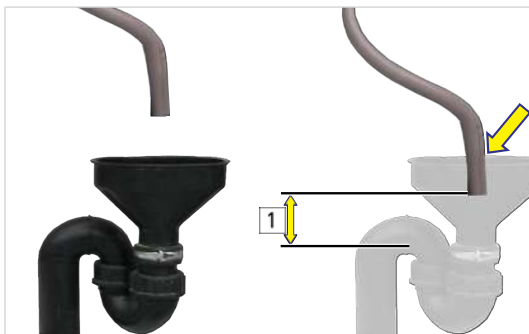

1. Insert the wastewater hose into the siphon (hygiene barrier) so that there is a free flow path [1] of at least 50 mm. The siphon still has to be ventilated.

2. Secure the wastewater hose in this position [arrow] to prevent it from sliding further into the siphon or from being pulled out accidentally.
3. Pour water into the drip tray and check the drain.

6.7 Connecting electrical circuit



WARNING

Risk of fatal injury from electrocution

Connecting to a power supply without a ground fault protective device can result in fatal injury from electrocution.

- a) Ensure that the connection to the power supply is protected by a ground fault protective device.



WARNING

Risk of fatal injury from electrocution

Work improperly performed on electrical systems can lead to electrocution.

- a) Trained and qualified electricians are permitted to work on electrical systems. Instructed persons are permitted to work on electrical systems only under the guidance and supervision of a trained and qualified electrician.



WARNING

Risk of fatal injury from electrocution

Damaged power cords, pipes or plugs can lead to electrocution.

- a) Do not connect any damaged power cords, pipes or plugs to the power grid.
- b) Replace damaged power cords, pipes or plugs.
If the power cord is permanently assembled, contact the service technician. If the power cord is not permanently assembled, order and use a new, original power cord.
- c) Ensure that the machine/appliance and the power cord are not near any hot surfaces such as gas or electric stoves or ovens.
- d) Ensure that the power cord is not pinched and does not chafe on sharp edges.
- e) Only pull on the plug and not on the cable when disconnecting the device from the power grid.

1. Fuse the electrical circuit.
2. Connect each appliance to the power grid separately.
3. Activate the electrical circuit.

6.8 Switching the machine on

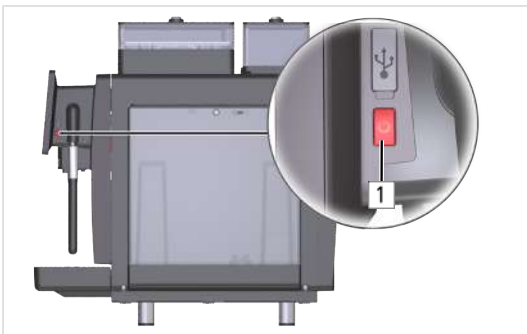

1. Briefly press the button [1].

⇒ The machine starts.

7 SWITCHING ON THE MACHINE FOR THE FIRST TIME



Once the machine is connected to the power grid, it switches itself on. When the machine is switched on for the first time, the software takes you through the basic settings that need to be configured when the machine is commissioned. All basic settings can be changed later:

Configuration

1. Connect the machine to the power grid.
 - ⇒ The machine starts up and launches the installation wizard.
2. Remove the protective film from the screen.
3. Configure the basic settings in line with the instructions on the operator panel – see table below.

Set language, time and Datum

Parameter	Value range	Remarks
Language	<ul style="list-style-type: none"> – de (German) – en (English) – fr (French) – ... Thirty-four languages are available	The language is switched immediately
12/24-hour display	12 hours 24 hours	
Time		
– Hour	0 – 23/0 – 11	Set the hour
– Minute	0 – 59	Set the minutes
Datum		
– Day	0 – 31	Set the day
– Month	0 – 12	Set the month
– Year	2019 – 9999	Set the year
Time zone		Select a time zone from the list

Water supply settings

Parameter	Value range	Remarks
Water hardness	Hardness levels 1 - 5	Enter the measured water hardness <i>Determining the water hardness with a measuring strip [28]</i> The water hardness must be set on machines that have a water tank and machines that are connected to the mains water connection but have no water filter
Water filter	<ul style="list-style-type: none"> – Yes – No 	Only in conjunction with main water connection

Parameter	Value range	Remarks
Filter quantity	Water filter type Selection list	Depends on the filter used and the water hardness

7.1 Fill resources



Only those resources that are available as per the configuration of the A300 are displayed.



The grind coarseness required depends on the beverage-preparation method, the type of roasted coffee used and the coffee beverage. It is a good idea to use separate grinders to make espresso, caffè crema and decaffeinated coffee. This enables a specific grind coarseness to be set for each different type of roasted coffee used. **Setting the grind coarseness [40]**

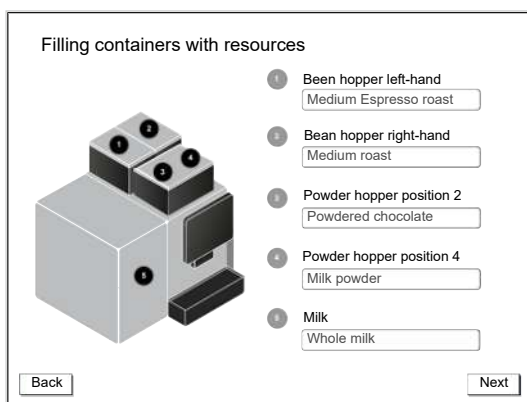

1. Fill the containers with the defined raw materials.

2. Tap Next.

⇒ You have now configured the most important settings and are ready to produce your first beverage.



To adjust the standard beverages, press on the Franke logo in the top left. See also the **Setting beverages [59]** chapter.

You can change any of the settings that you configured when commissioning the machine at any time by going to the Maintenance menu. **Configuration [58]**

7.2 Inserting a descaling cartridge

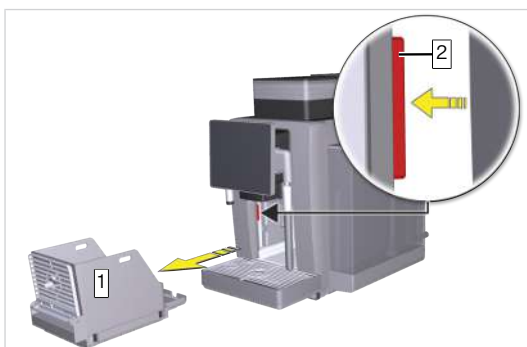

1. Remove the grounds container [1].

2. Open the door lock (option) with the key.

3. Press the latch [2] on the inside and open the door.

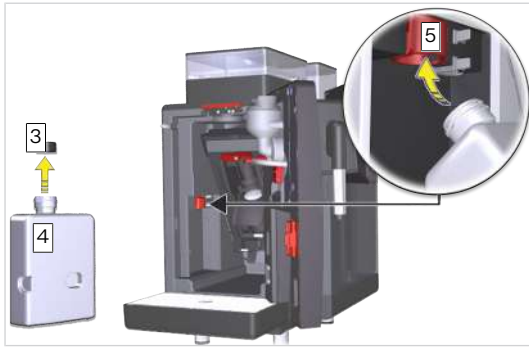

4. Unscrew the screw cap [3] from the cartridge [4].
5. Remove the seal.
6. Insert the descaling cartridge [4] at an angle from below into the red double pipe [5].
7. Close the door.
8. Insert the grounds container.

8 FILLING AND EMPTYING

8.1 filling the machine



NOTICE

Incorrect filling of the hoppers

Incorrectly filling the hoppers can produce defective products and the machine can be damaged as a result.

- a) Fill the bean hopper with coffee beans.
- b) Fill the powder hopper with powder suitable for automatic coffee makers.

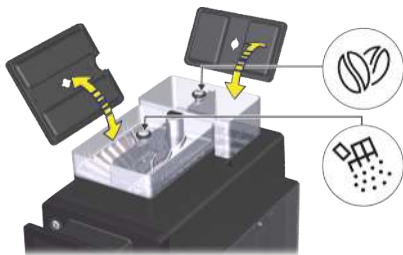

8.2 Filling beans



WARNING

Risk of injury

If objects find their way into the bean hopper or grinder, splinters may be ejected, leading to injury.

- a) Never insert any objects into the bean hopper or grinder.



NOTICE

Poor beverage quality

The oil from the coffee beans is deposited on the inside of the bean hopper as a thin film of oil. This deposited oil ages quickly and impairs the taste of the beverages produced.

- a) Remove the oil film from the inside of the bean hopper on a daily basis.
- b) To do this, use a dry cloth or a cloth moistened only with water.
- c) Do not use any cleaners, as these alter the taste of the coffee.



1. Lift off the bean hopper lid.

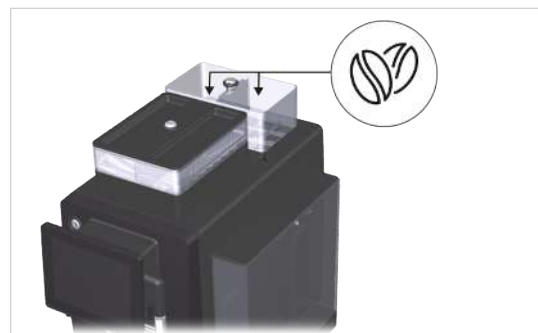

2. Fill coffee beans.

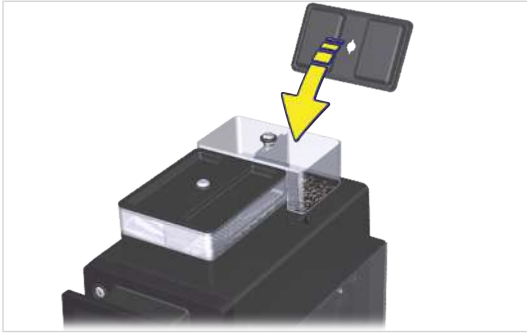

3. Fit the lid.

8.3 Using and storing roasted coffee beans



One crucial factor when it comes to optimal in-cup quality is the freshness of the roasted coffee beans used.

- a) Do not pour roasted coffee beans into the bean hoppers until you are just about to use the coffee machine. This ensures that you retain as much of the flavor as possible. Only pour in as much as you intend to use in the next few hours on the same day. Bean hoppers are not storage containers.
- b) Always close the bean hoppers properly. Make sure that you reseal open coffee packets properly after use.
- c) Store roasted coffee in a cool, dry place away from direct sunlight. Do not store it in a fridge.
- d) Order only as much roasted coffee as you need – ordering small quantities regularly ensures that you always drink coffee at its freshest.
- e) Order small package sizes, e.g. 250 or 500 g instead of 1 kg. This prevents open packs from being stored or too much roasted coffee being poured into the bean hoppers.

Monitor how much you use over a specific period, e.g. over the course of a week. Take note of when you need to refill and how much, and use this information to determine how much you will need over the next few hours. Mark the maximum fill level on each bean hopper, e.g. using a sticker.

8.4 Filling powder

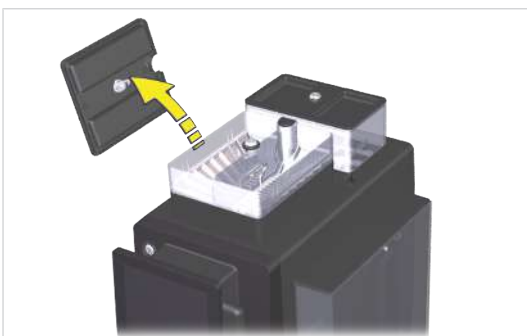

1. Lift off the powder hopper lid.

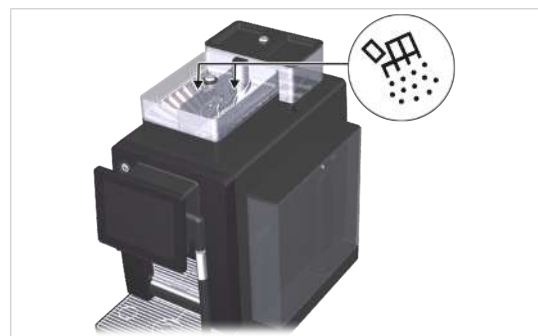

2. Fill with powder suitable for automatic beverage dispensers.

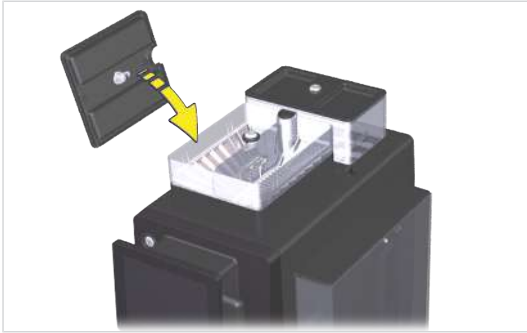

3. Fit the lid.

8.5 Filling the water tank



NOTICE

Machine damage

Pouring milk into the water tank can potentially damage the machine.

- a) Fill the water tank with water only.
- b) Disconnect the machine from the power supply and contact the service department if the water tank has been inadvertently filled with milk.



Optimal **Water quality [29]** is essential for the quality of the beverage, as well as for a long service life and reliable operation of the machine.

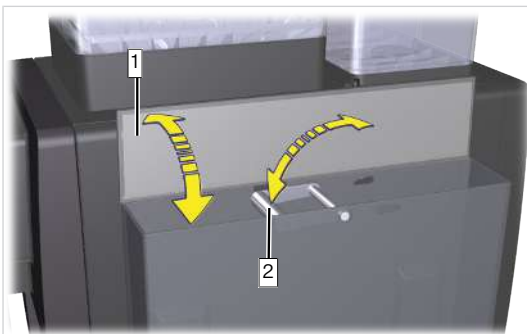

1. Open the lid [1] and open the handle [2].

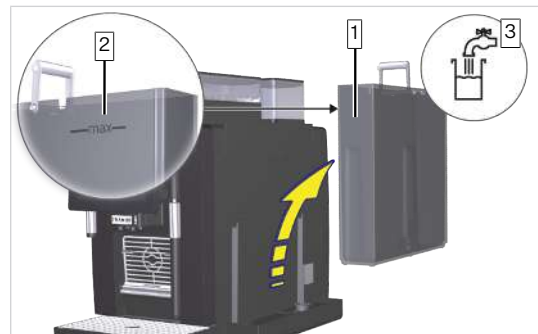

2. Remove the water tank [1] upwards and clean if necessary.
3. Fill the water tank with fresh water [3] up to the mark [2]. **Water quality [29]**
4. Attach the full water tank and close the lid.

8.6 Filling the cooling unit



CAUTION

Germs in unpasteurized milk

Germs in unpasteurized milk could pose a health hazard.

- a) Do not use any unpasteurized milk.
- b) Only use pasteurized or long-life milk.



NOTICE

Machine damage

Using incorrect liquids can damage the machine.

- a) Only fill the milk container with milk.
- b) Use water and a mild cleaner to clean the milk container.



NOTICE

Spoiled milk

Insufficient cooling or hygiene can cause milk to spoil.

- a) Only use precooled milk (2-5 °C).
- b) Only store milk in the cooling unit during operating hours. Outside operating hours, e.g. overnight, store the milk in a refrigerator.
- c) Clean the machine and cooling unit once a day.
- d) Only touch the suction hose, the inside of the milk container, and the milk container lid after sanitizing your hands, or when wearing single use gloves.
- e) Place the container lid with the suction hose on a clean surface only.



The milk system is prepared semi-automatically after a cleaning or a filling procedure. Please observe the instructions in the event messages. Access to the event messages is through the dashboard.

8.6.1 SU05 cooling unit



1. Open the door.

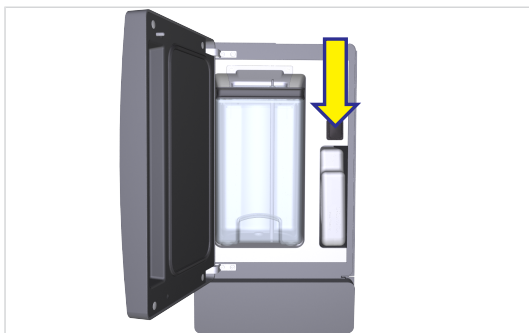

2. Switch on the cooling unit.



⇒ The current cooling chamber temperature is displayed.

3. Remove the milk container lid and suction hose and place them on a clean surface.
4. Fill the container with a maximum of 5 l of cooled milk.
5. Attach the milk container lid.



6. Push the milk container all the way into the cooling chamber.



7. Close the door.

8.7 Setting the grind coarseness



The grind coarseness can be adjusted individually for each grinder. Default setting: Center.

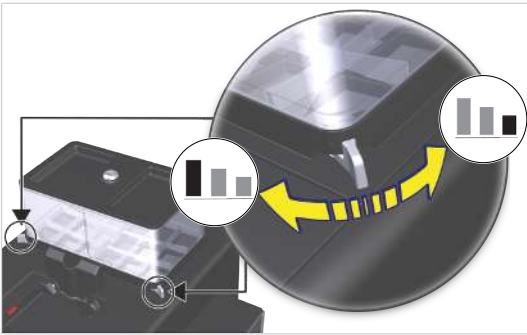

- For a finer grind, push the lever to the right.
- For a coarser grind, push the lever to the left.

8.8 Emptying the powder hopper



CAUTION

Cutting injuries/crushing

The powder hoppers worm gear mechanism can cause cuts or crushing injuries.

- a) Exercise care when cleaning the powder hopper.



NOTICE

Contamination from powder

Powder can fall from the powder hopper.

- a) Always transport the powder hopper in an upright position and ensure it is closed.

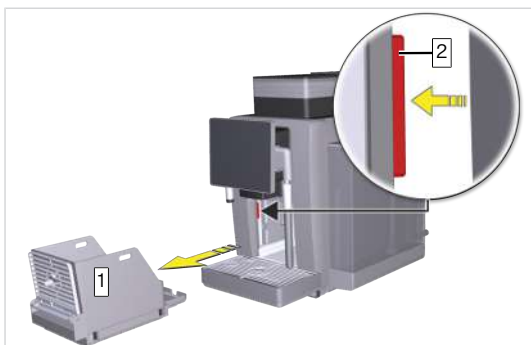

1. Remove the grounds container [1].
2. Open the door lock (option) with the key.
3. Press the latch [2] on the inside and open the door.

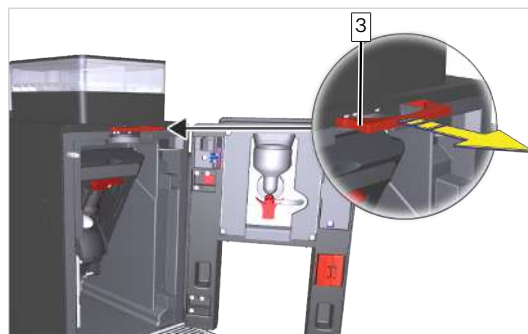

4. Pull the locking slide [3].

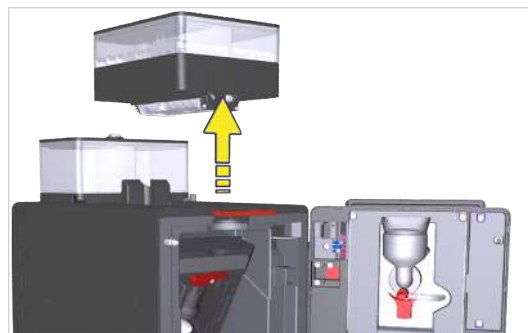

5. Lift and remove the powder hopper.
6. Empty, clean, and dry the powder hopper.
7. Attach the powder hopper.
8. Push the locking slide all the way in.



NOTICE

Impairment of function

If the powder hopper is not locked correctly, the function of the coffee machine and the product quality may be impaired.

- a) Push the locking slide all the way in.

8.9 Emptying the grounds container



NOTICE

Formation of mold

Coffee residue can lead to the formation of mold.

- a) Empty and clean the grounds container at least once a day.

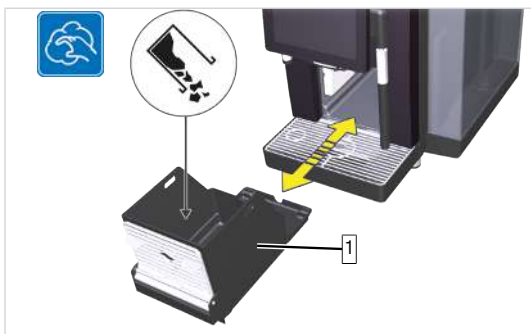

1. Remove and empty the grounds container [1].
2. Clean and dry the grounds container.
3. Insert the grounds container [1].

8.10 Empty the drip tray



Clean the drip tray when a message appears on the operator panel asking you to do so.



NOTICE

Improper handling

Liquid may leak out of the drip tray.

- a) Transport and empty the drip tray carefully.

- ✓ The Full drip tray message is displayed on the operator panel.

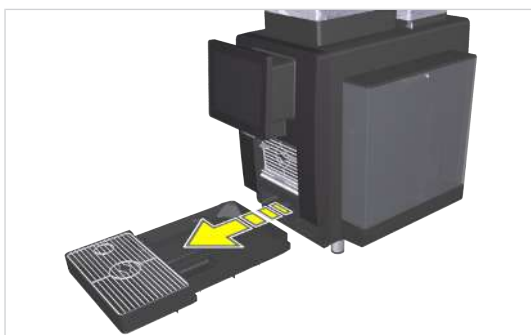
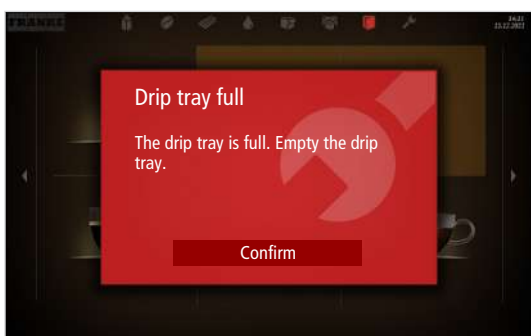

1. Pull out the drip tray.
2. Remove the drip grid.

3. Empty the drip tray.

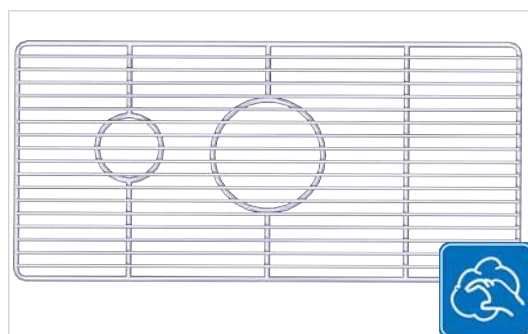

4. Clean and dry the drip tray and drip grid.
5. Place the drip grid on the drip tray.



6. Push the drip tray into the machine.

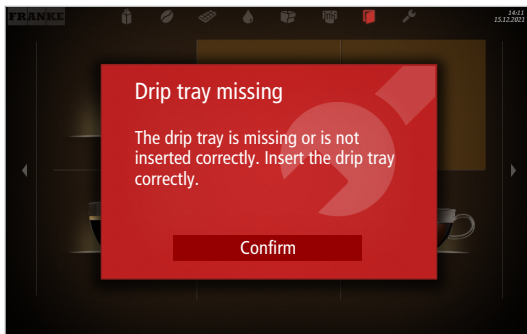

7. Tap Confirm.

8.11 Emptying the cooling unit



NOTICE

Spoiled milk

Insufficient cooling or hygiene can cause milk to spoil.

- a) Only use precooled milk (2-5 °C).
- b) Only store milk in the cooling unit during operating hours. Outside operating hours, e.g. overnight, store the milk in a refrigerator.
- c) Clean the machine and cooling unit once a day.
- d) Only touch the suction hose, the inside of the milk container, and the milk container lid after sanitizing your hands, or when wearing single use gloves.
- e) Place the container lid with the suction hose on a clean surface only.



NOTICE

Blockage of the milk system

Fibers from unsuitable cleaning cloths can enter the milk/media system and cause a blockage. This can damage the machine.

- a) Use a microfiber cloth to clean the milk container.

8.11.1 SU05 cooling unit



1. Open the door.

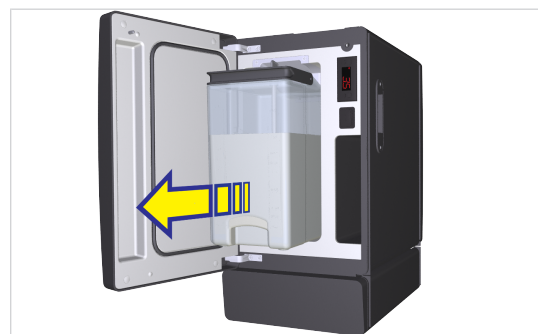

2. Pull out the milk container.

3. Keep the milk in a refrigerator, or dispose of it if necessary.



4. Clean the milk container, the parts that feed the milk into the system, and the cooling chamber.

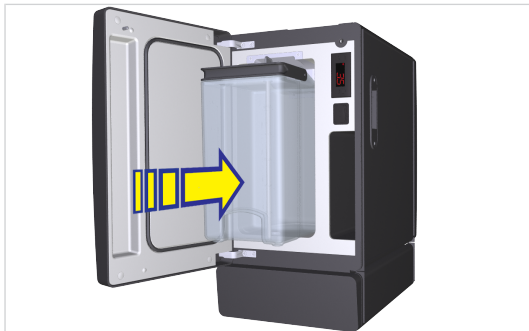

5. Insert the cleaned milk container.



6. Switch off the cooling unit if it is no longer required. Leave the door of the switched-off cooling unit slightly open to prevent odors from building up inside.

9 PREPARING BEVERAGES



WARNING

Risk of scalding

Hot beverages can lead to scalding.

- a) Always be careful with hot beverages.
- b) Use only suitable drinking vessels.

9.1 Preparing beverages with Quick Select

1. Place an appropriate drinking vessel under the dispensing spout.



2. Select a product.

⇒ The product preview will appear.



3. Select product options.

4. Press the green button to start preparation.

⇒ The beverage is being prepared.



⇒ The product selection screen appears when the product is ready.

9.2 Preparing beverages with Cash Register



When preparing several products one after the other, please observe the following:

- a) Have sufficient drinking vessels ready to use.
- b) You can continuously add new products to the waiting list during the preparation.
- c) You can select and clear products from the waiting list.

1. Place an appropriate drinking vessel under the dispensing spout.



2. Select the product options.



4. Add more products to the queue list as needed.



3. Select a product.

⇒ The preparation begins.



5. Start the preparation of each of the products in the queue list by pressing the green button.

⇒ The next preparation begins.

⇒ The product selection appears.

⇒ All products are ready.

9.3 Preparing hot water



You can stop the hot water spout at any time by pressing the cancel button.

Example: Quick Select

1. Place an appropriate drinking vessel under the hot water spout.

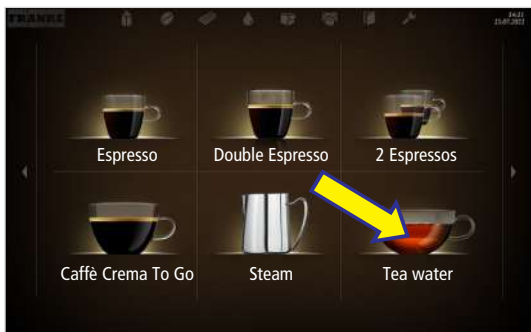

2. Select Tea water.



3. Select the cup size.

⇒ Hot water is dispensed until the cycle is complete.

9.4 Steam output



The steam wand is suitable for manually heating and foaming milk, as well as for heating other drinks.



Depending on the model of the steam wand, the steam output is automatically stopped when your drink has reached the specified temperature (Autosteam/Autosteam Pro) or the steam output cycle has ended (steam wand). Independent of this, the steam output can be ended at any time by pressing the cancel button.

1. Hold a milk pitcher under the steam outlet.

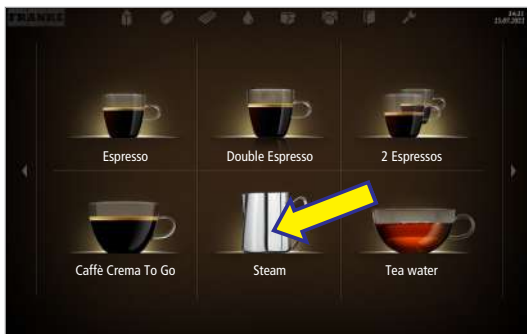

2. Select steam output.

⇒ The wand will start producing steam.



3. Press the cancel button to stop the steam output.

⇒ The steam output stops.

4. Press the purge button  and wipe the steam wand with a damp cloth.

9.4.1 Purging the steam wand after use

1. Wipe the steam wand with a damp cloth.
2. Start the steam output briefly to purge the nozzle.

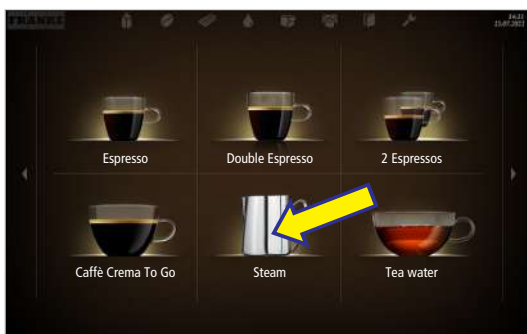

3. Press the cancel button to stop the steam.



⇒ The steam output stops.

⇒ The beverage overview screen appears.

10 CLEANING

10.1 Introduction

The perfect coffee experience depends on a perfectly cleaned coffee machine, cooling unit and Flavor Station (option). Increase your product quality! Clean your coffee machine and add-on units at least once a day and more frequently if necessary.

The automatic cleaning process includes the cleaning of the coffee machine and the cooling unit (if present).



NOTICE

Dirty components

Dirty components can have a negative effect on the function of the machine and the quality of beverages.

a) Clean the removable components using the 5-step method.



The removable components of the coffee machine, cooling unit, CleanMaster and Flavor Station (optional) are not dishwasher-safe.



Rinsing is not a substitute for daily cleaning! Rinsing is necessary to remove residue build-up in the coffee and milk systems.

The machine automatically rinses after certain time intervals as well as when it is switched on or off.

10.2 Required cleaning accessories

- Cleaning tablets
- Microfiber cloth
- Paint brush
- Brush set
- Cleaning agent cartridge (for cooling unit/Flavor Station with EC)
- Collecting container
- Cleaning container (SU05)

10.3 5-step method



Clean the removable components of your coffee machine using the 5-step method. The display shows you the components that can be removed during cleaning.

Clean the container and accessories of the cooling unit

Clean the containers and accessories, such as the lid, suction hose, suction nozzle, etc. using the 5-step method.

1. Remove coarse dirt with a cleaning brush or paint brush.
2. Soak the components in hot water with a mild cleaner.
3. Wash the components.
4. Rinse the components thoroughly.
5. Dry the components.

Additional areas to be cleaned by hand

- Inner side of the door and door gasket on cooling unit

- Inner surfaces and shelf (if applicable) in the cooling chamber

10.4 Starting the cleaning process



When the cleaning cycle is complete, the machine either switches back to the maintenance level or the energy saving mode. Your service technician can set the desired option for you.

10.4.1 Starting cleaning via the Cleaning and Maintenance menu



WARNING

Risk of scalding

Hot liquids and steam escape during cleaning and can lead to scalding.

- Keep hands away from the spouts and nozzles during this process.



1. Tap the Franke logo.



2. Enter the PIN. **PIN codes [58]**

3. Press Ok.

4. Select Cleaning and maintenance.

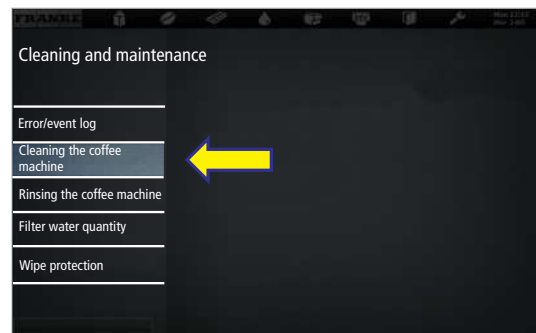

5. Select Clean coffee machine.
6. Confirm message with Yes to begin the cleaning process.
7. Follow the instructions on the user interface and confirm the completed steps by selecting Next.

⇒ The machine shows the next step.

10.5 Loosen bean hopper finger guard for cleaning



The bean hopper finger guard prevents injuries caused by the grinder. The finger guard may only be removed for cleaning.

- ✓ The coffee machine is switched off and disconnected from the power supply.
- ✓ A hexalobular 10 screwdriver is provided.

1. Remove the container lid.

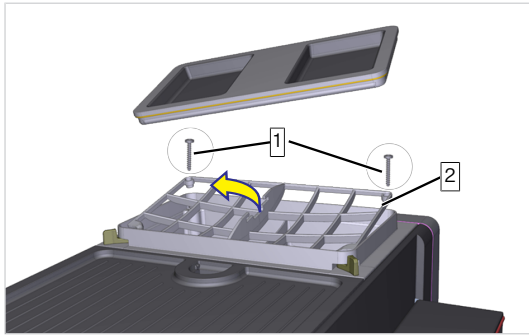

2. Loosen both screws [1] and remove the finger guard [2].
3. Clean the bean hopper and the protective grid.
4. Attach the dried finger guard with both screws.
5. Connect the coffee machine to the power supply.

10.6 Cleaning the aerator



1. Remove the aerator for hot water with the tool and descale.

2. Screw the aerator back in.

10.7 Weekly cleaning



Clean the machine components listed in this chapter at least once a week, in addition to the daily cleaning process. Clean the machine immediately if you notice any soiling.

10.7.1 Cleaning the machine surface

1. Clean the surface of the machine with a damp cloth.

2. If necessary, use a mild cleaner. **NOTICE! Do not use abrasive cleaners.**

10.7.2 Cleaning the water tank (if present)



Check the water tank daily for dirt or limescale. Clean the appliance immediately if it is dirty or has lime scale.



1. Remove and empty the water tank [1].
2. Clean the water tank using the 5-step method.

10.7.3 Cleaning the powder hopper

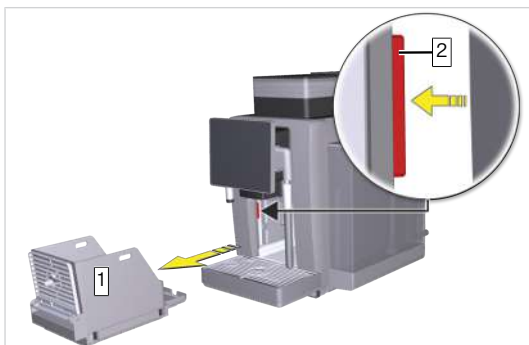

1. Remove the grounds container [1].
2. Open the door lock (option) with the key.
3. Press the latch [2] on the inside and open the door.

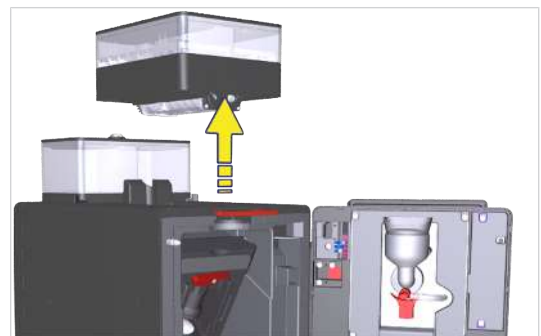

5. Raise and remove the powder hopper.
6. Empty the powder hopper.
7. Clean the powder hopper with a damp cloth. Wipe the inside of the hopper with a dry cloth.
8. Attach the powder hopper.
9. Push in the locking slide.
10. Close the door and insert the powder hopper.

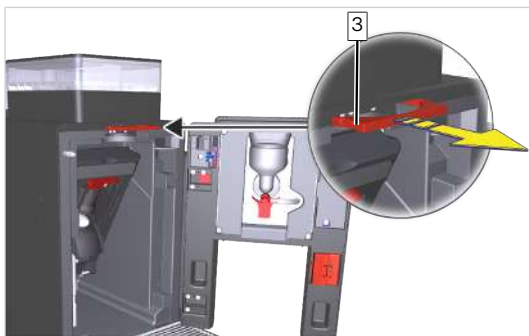

4. Pull the locking slide [3].

10.7.4 Cleaning the drip tray and drip grid.



NOTICE

Escaping liquid

Applies to machines with a wastewater connection! On machines with a wastewater connection, if water remains in the drip tray, this can escape when the drip tray is removed.

- a) Before removing the drip tray, ensure that the remaining water has drained.

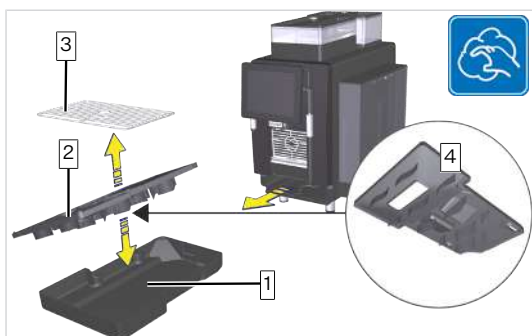

1. Clean the drip tray [1], the drip tray lid [2] and the drip grid [3] using the 5-step method.
2. Thoroughly clean the projecting features on the underside [4] of the drip tray lid [2].



The rear of the drip tray [1] must be clean and dry, both inside and out. If it is not, this may cause the drip tray's continuous level sensor to issue an alert in error.

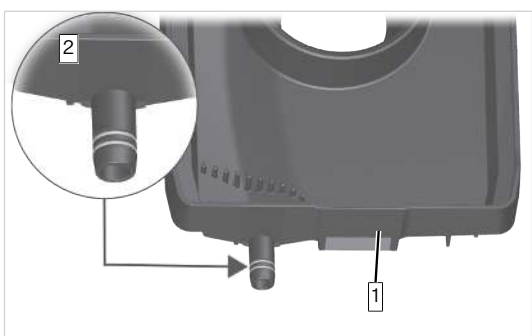

If the coffee machine is connected to the wastewater system, there are two O-rings on the back of the drip tray [2]. These must be moistened with water so that the drip tray can fully engage. Otherwise, the capacitive sensor cannot detect the drip tray.

10.7.5 Cleaning the screen



1. Tap the Franke logo.



2. Enter the PIN. **PIN codes [58]**

3. Press Ok.
4. Select Cleaning and maintenance.

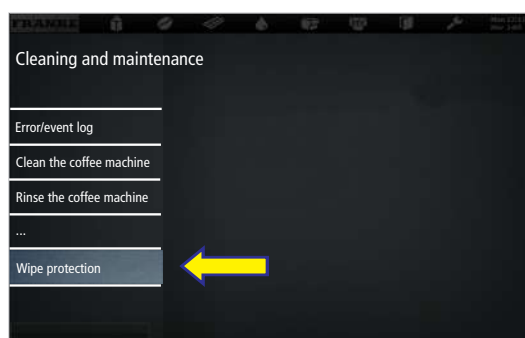

5. Select Wipe protection.
 - ⇒ The user interface is locked for 20 seconds.
6. Clean the screen.
 - ⇒ The maintenance level appears.

10.8 Rinsing the coffee machine



WARNING

Risk of scalding

Hot water is released during rinsing.

- a) Keep hands away from the spouts and nozzles during this process.
- b) Do not place anything on the drip grid.
- c) IN CASE OF SCALDING: Immediately cool the affected area and, depending on the severity of the injury, consult a doctor.



Rinsing is not a substitute for daily cleaning! Rinsing is necessary to remove residue build-up in the coffee and milk systems.

The machine automatically rinses after certain time intervals as well as when it is switched on or off.



1. Tap the Franke logo.



2. Enter the PIN. **PIN codes [] 58]**

3. Press Ok.

4. Select Cleaning and maintenance.

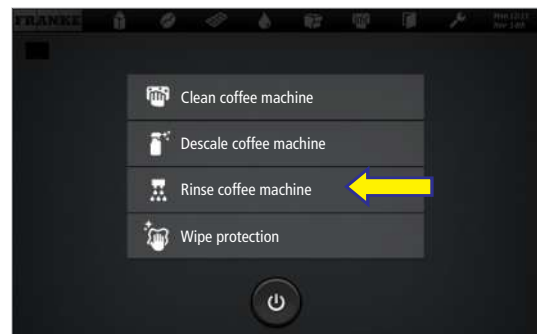











5. Tap Rinse coffee machine and confirm.

⇒ The coffee machine is rinsed.

10.9 Care kit



Over time, some of the coffee machine's components may be subject to wear or may become very dirty, and will need to be replaced. This may be the case even before the service technician is due to carry out scheduled maintenance work. We have compiled a list of the parts in question to make it easy to reorder them. You can replace the following components yourself.

Image	Quantity	Item number	Item description	Remarks
	1	560.0637.018	Brewing module Ø 43 with 0.6 mm orifice	The item number can be found on the label on the side of the brewing module. The following section describes the necessary steps. Replacing the brewing unit [55]
	1	560.0001.697	Brewing module Ø 50E with 0.6 mm orifice	The item number can be found on the label on the side of the brewing module. The following section describes the necessary steps. Replacing the brewing unit [55]
	2	560.0578.001	O-ring 13x1.5 EPDM	Seal for drip tray with drain Only for versions with a main water connection Cleaning the drip tray and drip grid [51]
	1	560.0001.187	Mixing chamber	For powder system
	1	560.0580.820	Mixer chamber lid	For powder system
	1	560.0593.645	FCS4070 FM EC frother head	See type plate to find out which version (FM or MS). The type plate is located inside the machine. Coffee machine [18]
	1	560.0594.309	FCS4070 MS EC frother head	See type plate to find out which version (FM or MS). The type plate is located inside the machine. Coffee machine [18]
	1	560.0589.901	FCS4070 double milk spout	FM and MS versions are identical
	1	560.0613.850	FCS4070 single milk spout	
	1	560.0001.074	Suction hose, assembled, 300 mm	Milk suction line for SU05 cooling unit Parts of the cooling unit [22]
	1	560.0003.688	Hose Ø 8/4 MVQ	1,000 mm suction hose for all other milk systems. Shorten the hose as required. The KE200 cooling unit requires a hose that is 400 mm long.

10.9.1 Replacing the brewing unit

1. Empty the machine and disconnect it from the power grid.
2. Remove the grounds container from the machine.
3. Open the machine's door.

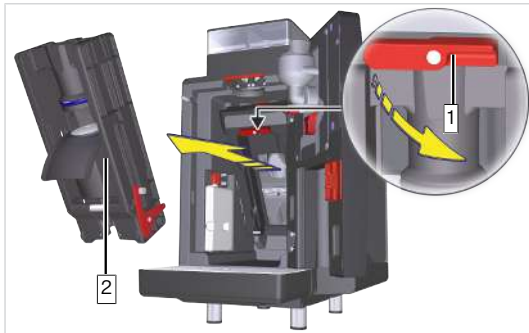

4. Release the brewing module lock [1] in counterclockwise direction.

5. Take out the brewing module [2] by pulling it forwards.
6. Insert the new brewing module [2].
7. Turn the brewing module lock [1] clockwise to fix it.
8. Close the door of the machine.
9. Insert the grounds container into the machine.
10. Connect the machine to the power grid.

11 DESCALING

To maintain consistently high in-cup quality and ensure that the coffee machine runs reliably, the machine must be descaled regularly. For this purpose, the A300 has an automatic descaling system. If descaling is necessary, the coffee machine indicates this on the operator panel. Limescale deposits can form in the heating cartridge in particular.



To descale the machine, only use the descaler concentrate from Franke (item number 560.0589.837). This guarantees reliable descaling results.

- a) Make sure that you order descaler concentrate in good time so that you can descale the coffee machine immediately when the prompt appears on the coffee machine operator panel.

11.1 Descaling due date

When commissioning the A300, you will be prompted to measure the water hardness and to enter this into the software.

Determining the water hardness with a measuring strip [28]

This value is used to calculate the amount of water until the machine will next need to be descaled.

Machines without a water filter

A descaling prompt is displayed when the calculated water quantity is reached or, at the latest, after 12 days of operation. The A300 can be used for another 2 days after the descaling prompt is first displayed. After this period, the machine is disabled until descaling is carried out.

Machines with a main water connection and water filter

A descaling prompt is displayed after 12 days of operation. After the descaling prompt is first displayed, the A300 can continue to be used until the remaining water is used up. After this period, the machine is disabled until descaling is carried out.

11.2 Descaling

If descaling is necessary, a message is displayed on the operator panel. The message can be closed so as not to disrupt operation. The following options are available for starting the descaling process:

- Descaling when cleaning is next carried out (default setting)
- Descaling independently of cleaning – descaling is started automatically at a specified time
- Manually starting descaling



NOTICE

Discontinuing descaling

Applies to machines with a water tank: If the water tank is empty or the drip tray is full, automatic descaling is not carried out.

- a) Empty the drip tray before cleaning/descaling.
- b) Fill the water tank before cleaning/descaling.
- c) Position the cleaning container on the drip grid in accordance with the instructions on the operator panel.

11.2.1 Descaling after cleaning

With the default setting, when descaling is due it is initiated straight after cleaning is next carried out without requiring any further confirmation. No additional action is required on the part of the operator. Descaling takes approx. 15 - 25 minutes, depending on the machine model. If descaling is due, the system

checks whether there is sufficient descaler concentrate before the cleaning process begins. If there is insufficient descaler concentrate, a prompt to replace the descaling cartridge is displayed. **Inserting a descaling cartridge [34]**

11.2.2 Descaling independent of cleaning



To prevent the descaling process from disrupting operation, your service technician can set a time for the descaling process to run outside of your operating hours.

11.2.3 Initiating descaling manually



WARNING

Risk of scalding

Hot liquids and steam escape during descaling and can lead to scalding.

- a) Keep hands away from the spouts and nozzles during this process.



1. Tap the Franke logo.



2. Enter the PIN. **PIN codes [58]**

3. Press Ok.

4. Select Cleaning and maintenance.

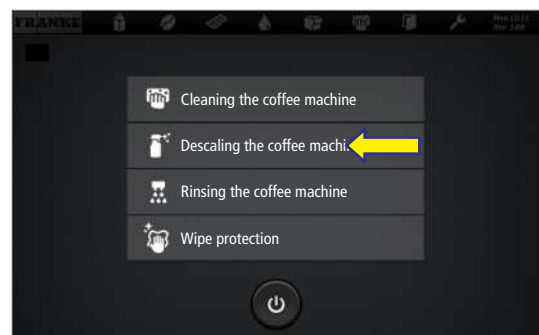

5. Select Descaling.

- ⇒ The automatic descaling process starts and instructions are displayed regarding the next steps to be taken.

12 CONFIGURATION

12.1 Calling up the maintenance level



1. Tap the Franke logo.



2. Enter the PIN. **PIN codes [58]**

3. Press Ok.

12.2 PIN codes

Default PIN codes are assigned at the factory:

	Owner	Specialist	Cleaning staff	Operator
Default PIN	1111	2222	5555	7777
My PIN

The PINs for key (secured) products and On/Off machine can be viewed and changed with the owner role in the My settings > Access rights menu.

12.3 Input methods

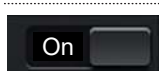

Tap the switch to switch between Yes/No or On/Off. The visible value is active.



Tap the arrow to display the selection and to select the option.

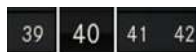

Drag the scale to adjust parameters. The framed value is active.



Tap the keyboard to enter text or numbers.



Press the button to carry out the corresponding settings, e.g. Start, Test.

12.4 My settings

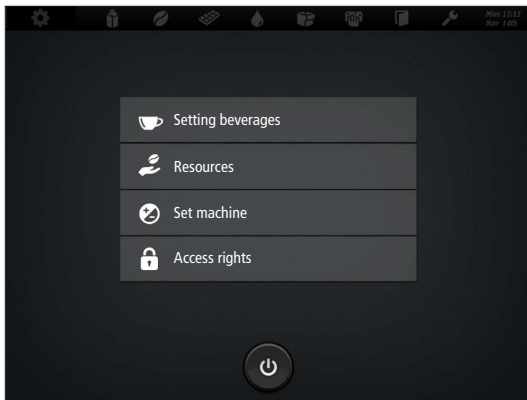

12.4.1 Setting beverages



Action	Input/function	Remarks
Export/import	<ul style="list-style-type: none"> – Back up product offering package (POP) – Load backup 	<ul style="list-style-type: none"> – Back up beverage settings to a USB stick, e.g., before a software update – Load beverage settings from a USB stick to the coffee machine
Sort beverages		<ul style="list-style-type: none"> – Change the positions of the beverages – Set the number of beverages to be displayed (2 x 3, 3 x 4 or 4 x 5) <ol style="list-style-type: none"> 1. Tap the Sort beverages button. 2. Tap the beverage you wish to move. 3. Tap the desired position for the beverage.
Edit		Modify the highlighted beverage
Display/hide		Show or hide available beverages

Action	Input/function	Remarks
Copy		Copy existing beverages to use as the basis for a variant
Adjustable	<ul style="list-style-type: none"> - Yes - No 	Activate/deactivate. When this function has been activated, a beverage can be modified in the following ways after being selected: <ul style="list-style-type: none"> - Cup size - Type of bean, if more than one bean type has been configured - Aroma strength
		Quick Select operating mode

Modifying a beverage



1	Active beverage	2	Resource (coffee, milk, etc.)
3	Configuration parameters	4	Slide control

12.4.2 Set resources



You can change the settings that you configured when commissioning the machine (Refilling containers with resources) at any time.

For each container, a list of available resources is stored from which you can choose.

Allocate resources

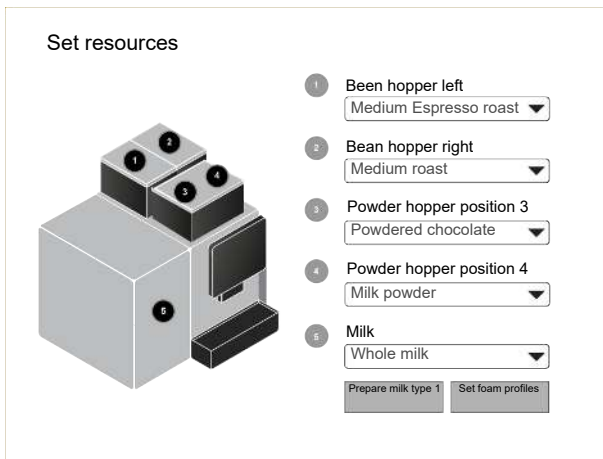

1. To allocate a resource to a container, tap the preset resource type.
2. Select the appropriate resource type from the list.
3. Repeat this process for all containers.
4. To fill the milk lines, select Prepare milk type 1.

Set foam profiles



On the A300 FM EC, you can set the foam profiles for firm and liquid foam (standard settings: Liquid foam 10% air, firm foam 35% air).

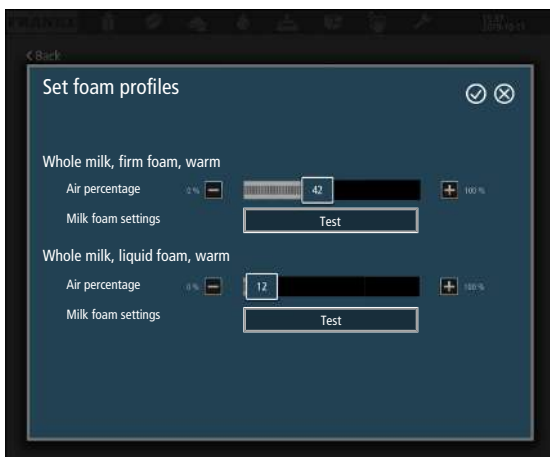

1. Tap Set foam profiles.
2. Use the slide control to set the air percentage in firm and liquid foam.
3. Click Test to check whether the foam has the quality you require.
4. Repeat this process if necessary.

12.4.3 Set machine

Language

Parameter	Value range	Remarks
Language	<ul style="list-style-type: none"> - de (German) - en (English) - fr (French) - ... Thirty-three languages are available	The language is switched immediately

Date and time

Parameter	Value range	Remarks
12/24-hour display	12 hours 24 hours	
Date		
- Day	0 - 31	Set the day
- Month	0 - 12	Set the month
- Year	2019 - 9999	Set the year
Time		
- Hour	0 - 23/0 - 11	Set the hour
- Minute	0 - 59	Set the minutes
Time zone		Select a time zone from the list

Timers

Basic settings

Parameter	Value range	Remarks
Saving energy	<ul style="list-style-type: none"> - Active - Off 	If Active, the waiting time can be set Range: 15 - 120 minutes
Switch on/off automatically	<ul style="list-style-type: none"> - Active - Off 	<ul style="list-style-type: none"> - Switch timer on or off - Use the pin to adjust the timer

Adjusting timers

Parameter	Value range	Remarks
Action	<ul style="list-style-type: none"> - Switch on automatically - Switch off automatically 	Select timer operation
Hour	0 - 23	Set switch-on/switch-off time
Minute	0 - 59	
Repeat every Monday	- Yes	Activate/deactivate the timer depending on the day

Parameter	Value range	Remarks
...	- No	
Repeat every Sunday		

Water settings

Water supply settings

Parameter	Value range	Remarks
Water filter active	- Yes - No	- Yes: Slide control appears for entering the duration of use/the water quantity for the water filter (depending on the filter used) - No: Set water hardness
Water hardness	Hardness levels 0 - 5	Set the measured water hardness on the slider Determining water hardness using measuring strips The water hardness must be set on machines that have a water tank and machines that are connected to the mains water connection but have no water filter

Factory settings

Parameter	Value range	Remarks
Reset to factory settings		All settings, including your own products, will be lost!
Reset products to factory settings		Your own product settings will be lost!

System information

Category	Value
Total version	Machine software version that is currently installed
Sub-system versions	
Machine	Machine type
Serial number	[Serial number]
FPC	Franke product catalog version that is currently installed
POP (product offering package)	Product offering package version that is currently installed (product positioning/sorting)
License	Active license for Franke Digital Services, if present
Ethernet device A	
IP address	
MAC address	

12.4.4 Access rights

The roles are organized into the following hierarchy: Service technician > Owner > Operator > Maintenance staff.

Roles and rights

Action	Service technician	Owner	Specialist	Operator
Change PIN and activate test products	Yes (for all roles)	Yes (for child roles)	No	No
Add/change/re-move/adapt products	Yes	Yes (reduced functionality)	No	No
View counter	Yes	Yes	Yes	No
Perform cleaning	Yes	Yes	Yes	Yes
Perform software update (USB)	Yes	No	Yes	No

13 INDIVIDUALIZATION AND DATA TRANSFER

13.1 Overview

This menu provides you with the following options:

- Use existing Franke media for screen savers or as advertising media
- Upload and view your own media objects on the machine
- Use your own media for screen savers or as advertising media
- Configure the behavior of the different operating modes and the screen saver
- Save settings
- Create regular backups of your machine to a USB stick
- Perform downloaded digital services updates

13.2 Multimedia functions

- Use image files as advertising media
- Use image files as screen saver

13.3 Manage Digital Signage via USB stick

You can maintain the selection and display times of your advertising media (digital signage) in a freely accessible web tool. To do this, export and import the corresponding file with a USB stick.

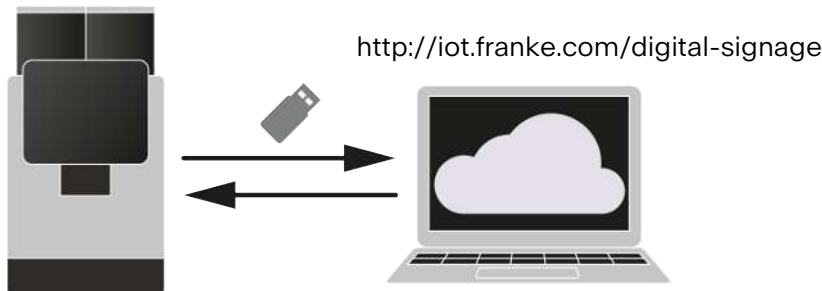

- ✓ The coffee machine has software version 4.0 or higher.
- 1. Connect a USB stick to the machine.
- 2. Go to menu item Individualization and data transfer > 1 Digital Signage.
- 3. Tap the Export Digital Signage button.
- 4. For the parameter Eject USB stick select the value Yes.
- 5. Tap the Export button.
 - ⇒ The coffee machine saves the *.bundle file to the USB stick.
- 6. Remove the USB stick.
- 7. Connect the USB stick to any computer.
- 8. In the browser, go to the website <http://iot.franke.com/digital-signage>.
- 9. Transfer the *.bundle file from the USB stick to the website via drag&drop or file explorer.
 - ⇒ The configuration options for Digital Signage are displayed.
- 10. Make the desired settings.
- 11. Rename the file via the pencil icon in the upper left-hand corner, if desired.
- 12. Tap the Download button on the bottom left side of the window.

- ⇒ The web page asks whether the changes made should be saved.
- 13. Confirm the question.
- 14. Select the **Manual** value.
- 15. Tap the **Download bundle** button.
 - ⇒ The downloaded *.bundle file ends up in the download folder of the computer.
- 16. Move the *.bundle file to the USB stick.
- 17. Remove the USB stick.
- 18. Connect the USB stick to the machine.
- 19. Go to menu item **Individualization and data transfer > 1 Digital Signage**.
- 20. Tap the **Import Digital Signage** button.
- 21. Select the revised *.bundle file.
- 22. Tap the **Download and install** button.
 - ⇒ The coffee machine adopts the new settings.

13.4 Configure application



Changes made will only take effect after the **Save** button is tapped.

13.4.1 Language settings

Parameter	Value range	Remarks
Language	– All available languages	
Switching language	– Yes – No	– Yes: a country flag appears in the top right corner during product selection. The languages defined under Language 1-6 appear by tapping the flag. If a language is selected, the translated beverage names and billing information will appear. After the duration specified under Timeout language switching has elapsed, the default language specified under Language reappears. – No: language switching is deactivated
Timeout for language change	20–120 s	Waiting time after which the coffee machine switches back to the default language set in Language or under the menu 1 Set machine > 1.1 Language .
Language 1-6	de, en, fr, bg, cs, da, es-ES, es-US, et, fi, fr-CA, hr, hu, it, ja, ko, lt, lv, nl, no, pl, pt-BR, ro, ru, sk, sl, sr, sv, tr, th, uk, zh-CN, zh-TW, ar, he	– Appears only if the value Yes is selected for Language change – Determines how many and which alternative languages are available during product selection

13.4.2 Operating mode

Parameter	Value range	Remarks
Operating mode	<ul style="list-style-type: none"> - Self-service – Quick Select - Non-self-service – Cash Register 	
Hide cancel button	<ul style="list-style-type: none"> - Yes - No 	
Display clock	<ul style="list-style-type: none"> - Yes - No 	
Display brightness	15-100 %	
Audible signal for beverage preparation	<ul style="list-style-type: none"> - Yes - No 	
Audible signal for error messages	<ul style="list-style-type: none"> - Yes - No 	

13.4.3 Display [Operating mode]



Depending on the operating mode, different display parameters are available.

13.4.4 Nutritional value settings

Parameter	Value range	Remarks
Display nutritional value information	<ul style="list-style-type: none"> - Yes - No 	<ul style="list-style-type: none"> - Activate/deactivate the display of nutritional value information - The nutritional information can be entered in chapter Menu 4 Nutritional value information
Further nutritional value information	Free text input	

13.4.5 Accounting

Parameter	Value range	Remarks
Select	<ul style="list-style-type: none"> - Coins - Cards - Customer card - Contactless - Cell phone - Bills 	

Parameter	Value range	Remarks
Display pop-up window	<ul style="list-style-type: none"> - Yes - No 	Activate/deactivate accounting pop-up window

13.4.6 Transaction approval (API)



Parameters are not related to each other

The parameters Activate transaction approval and Allow Remote Control can cover similar use cases. However, the parameters are not related to each other.

Parameter	Value range	Remarks
Activate transaction approval	<ul style="list-style-type: none"> - Yes - No 	The transaction approval enables interaction between the coffee machine and the third-party app. The use case is the same as for Remote Control, but instead of the Franke web app, the app from a third-party manufacturer is used.
Allow Remote Control	<ul style="list-style-type: none"> - Yes - No 	With Remote Control, the coffee machine refers to a QR code that leads to Franke's web app. The web app enables both beverage selection and payment via cell phone. Once payment has been successfully processed, the app triggers the beverage production.

13.5 Loading/backing up data

13.5.1 Back up data

Desired action	Menu item	Information/instruction
Export a configuration and media	3.1 Back up data	<ul style="list-style-type: none"> - Export configuration - Back up Franke media - Back up your own media - Eject USB stick automatically - Display of file name

13.5.2 Load data

Desired action	Menu item	Information/instruction
Import configuration and media	3.2 Load backup	<ul style="list-style-type: none"> - Load backed up data (configuration, Franke media, your own media) - Eject USB stick automatically

13.5.3 Back up XML data

Desired action	Menu item	Information/instruction
Back up XML data	3.3 Back up XML data	Export operating data such as maintenance data, error logs, or product and machine counters <ul style="list-style-type: none"> - Eject USB stick automatically - Display of file name

13.6 Set default values

Desired action	Menu item	Information/instruction
Set default values	4 Set default values	In the selected areas, restore the default values (e.g. variable and fixed data) or delete counters (product and machine counters) and files (product and error log, files) <p>Confirm changes made by tapping the Apply button</p>

13.7 Activating configurations

If updates (menu bundle, software version, etc.) are transferred to the coffee machine via Dashboard Provisioning or Deployment or via USB stick, they must be activated on the coffee machine. The available update packages can be viewed in the Individualization and data transfer menu on the coffee machine.

✓ A configuration, a menu bundle, or a new software version was loaded onto the coffee machine via the Provisioning or Deployment dashboard.

1. Tap the Franke logo.
2. Enter the PIN.
3. Press OK.

⇒ In addition to the Individualization and data transfer menu, the number of available updates can be viewed.

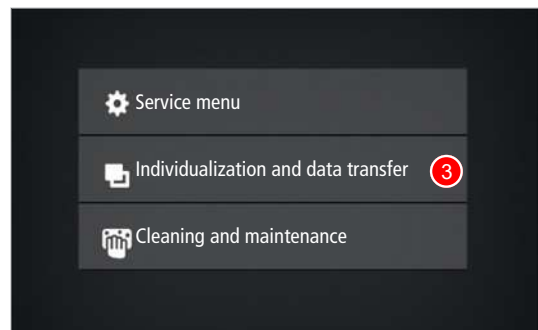

4. Select the Individualization and data transfer menu.
5. Select menu item 9 Update packages.
6. Select the desired update package and press the Download and import button.
 - ⇒ The update package is imported.
7. Press the Install button.
 - ⇒ The update package is installed.

14 TROUBLESHOOTING

14.1 Error messages

If an error occurs, a symbol on the dashboard is highlighted in a particular color, depending on the type of error. The user can tap on this to display a window with further information and troubleshooting instructions.

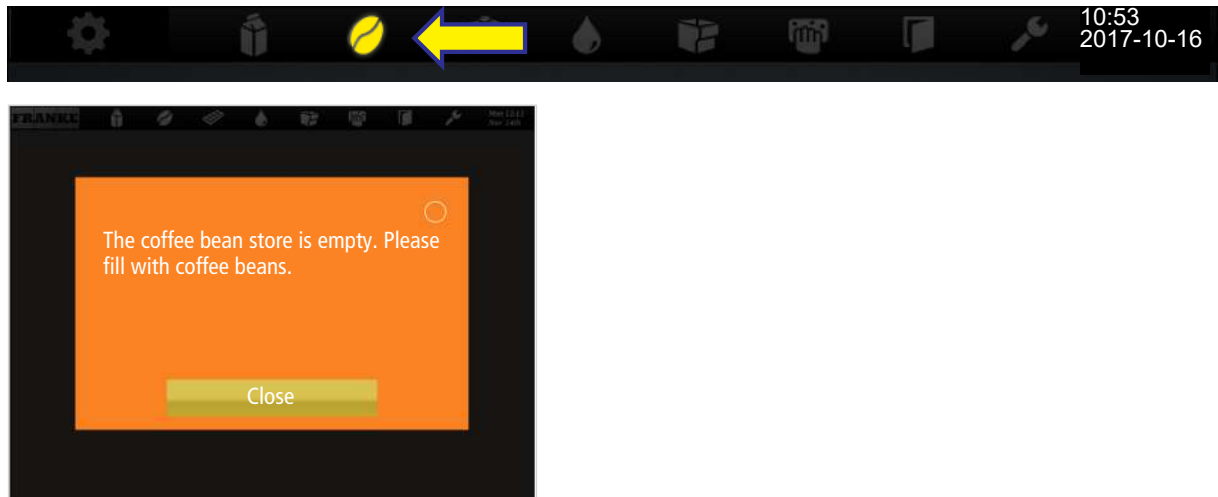

Message with instructions

Non-self-service mode

Errors in the non-self-service mode are indicated via a highlighted symbol. Tap the symbol for further information.



Self-service operating mode

When the self-service mode is selected, an error is indicated via a colored triangle in the upper right-hand corner of the operator panel. Tap the symbol for further information.

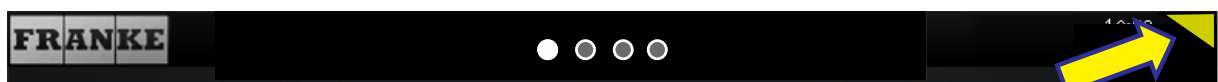

The machine must be restarted in the event of serious errors.

- a) Restart the machine.
- b) Check the power supply if the machine fails to start.
- c) Contact your service technician if the machine cannot be started or if you are unable to rectify the error.

14.1.1 Color code for error messages

- Temporary interruption

- System still fully functional

- System has limited functionality

- Some or all resources are locked

14.2 Troubleshooting the system

Error message/problem	Possible cause	Measure
Error message E663 empty drip tray appears even though the drip tray has been emptied	Sensor signal disturbed by debris inside the drip tray	Clean and dry the inside of the drip tray. Additionally, clean and dry the mounting bay of the drip tray
	Sensor signal disturbed by damp back of the drip tray	Clean and dry the back of the drip tray
Milk is frozen	Cooling unit target temperature is set too low	Set target temperature 1–2 °C higher <ul style="list-style-type: none"> – SU05 cooling unit: Press and hold the Set button on the temperature controller until the target temperature flashes. Use the navigation buttons to increase the target temperature. Use the Set button to confirm the new target temperature. – KE200: A temperature controller is located to the rear of the KE200. Use this to set the required temperature
		The cooling unit door seal is not leak-tight
	Cooling unit milk temperature is not being reached	Inadequate air circulation around cooling unit
No milk or just milk foam	Suction hose/milk line has a leak	Check the position of the spout insert and, if necessary, clean it. SU05 cooling unit: Check the O-ring on the suction hose coupling. Check the suction hose and, if necessary, replace it
Milk is not flowing correctly out of the milk spout	The milk spout was not installed correctly when it was last cleaned	Start coffee machine cleaning, and install the milk spout as per the instructions on the touch screen.
Descaler concentrate not being dispensed (error message E409)	Descaling cartridge seal is damaged or clogged or descaling cartridge is empty	Check the descaling cartridge fill level. Check the red adapter with the sealing ring and clear away any descaler crystals. Run the descaling process again

Error message/problem	Possible cause	Measure
Descaling cartridge needs replacing despite not being empty	Descaling cartridge seal is damaged or clogged	Insert a new descaling cartridge, check the red adapter with the sealing ring and remove any descaler crystals
Error message E79 Flow meter error	Water flow disrupted	<p>Check the water tank/main water connection coupling</p> <p>If the error message appears while a product is being dispensed, the brewing module strainer is probably blocked</p> <ul style="list-style-type: none"> – Increase the grind coarseness and/or reduce the grind quantity – Remove the brewing module and rinse it out – Start the coffee machine cleaning process
Touch screen not responding correctly	Overloaded machine software	<p>There are two different troubleshooting methods:</p> <ul style="list-style-type: none"> – Method 1: Press and hold the red button on the right-hand side of the operator panel for 10 seconds to restart – Method 2: Disconnect the coffee machine from the power grid. Wait 1 minute before reconnecting the coffee machine to the power grid. Briefly press the red button on the right-hand side of the operator panel to switch it on
Water level in the water tank is not detected	Residues or deposits on the inner wall of the water tank	Clean and rinse the water tank thoroughly

14.2.1 Restarting the machine

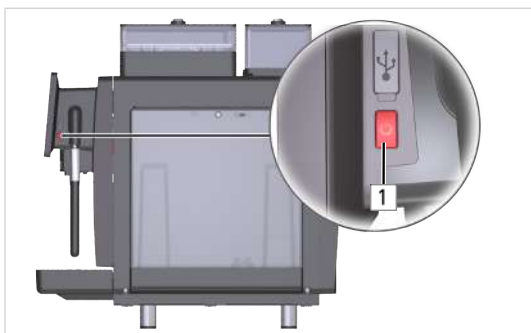

1. Press and hold the button [1] for 10 seconds.

- ⇒ The machine will restart.
- ⇒ The start screen is displayed.

14.3 Tips for good coffee beverages



NOTICE

Poor beverage quality

The oil from the coffee beans is deposited on the inside of the bean hopper as a thin film of oil. This deposited oil ages quickly and impairs the taste of the beverages produced.

- a) Remove the oil film from the inside of the bean hopper on a daily basis.
- b) To do this, use a dry cloth or a cloth moistened only with water.
- c) Do not use any cleaners, as these alter the taste of the coffee.



The aromas of the coffee beans evaporate in the bean hopper as a result of heat and air exchange. The quality will have already deteriorated after 3 hours.

- a) Coffee beans should not be moist.
- b) Seal any open coffee bean packs in an airtight manner.
- c) Do not store coffee beans in a refrigerator or freezer.
- d) Only fill the coffee beans into the bean hopper that you will need for the next 3 hours.

14.4 Help with problems concerning product quality

Problem	Possible causes	Possible remedies
Coffee tastes stale	Grind too coarse	Select a finer grind Setting the grind coarseness [40]
	Too little coffee	Increase coffee quantity Setting beverages [59]
	Temperature too low	Increase temperature Setting beverages [59]
	Coffee is old	Use fresh coffee
	Bean hopper not locked correctly	Check the bean hopper latching mechanism
Coffee tastes strange	Poor grind	Contact customer service
	Minimal coffee usage	Fill a small amount of coffee beans into the bean hopper
	Spoiled coffee beans	Replace coffee beans
	Cleaner residue	Rinse the machine
	Dirty cup	Check the dishwasher
	Poor water quality (chlorine, hardness, etc.)	Have water quality tested Water quality [29]
Coffee tastes bitter	Temperature too high	Reduce coffee temperature Setting beverages [59]
	Grind too fine	Select a coarser grind Setting the grind coarseness [40]

Problem	Possible causes	Possible remedies
	Coffee quantity too low	Increase coffee quantity Setting beverages [59]
	Roast too dark	Use lighter coffee roast
Coffee tastes sour	Temperature too low	Increase coffee temperature Setting beverages [59]
	Roast too light	Use darker coffee roast
	Grind too coarse	Select a finer grind Setting the grind coarseness [40]
Consistency of powder products	Viscous	Use less powder, use more water
	Watery	Use more powder, use less water
	Powder clumping or moist	Clean and dry powder system
Taste of powder products	Too sweet	Use less powder, use more water
	Not sweet enough	Use more powder, use less water
	Strange taste	Clean powder system

15 DECOMMISSIONING

15.1 Preparing for decommissioning

1. Clean the machine using the automatic **Cleaning [48]** function.
2. Empty the bean hopper and powder hopper.
3. Clean the bean hopper and powder hopper.
4. Clean the grounds container.
5. Empty the milk container.
6. Clean the milk container and container lid.
7. Clean the inside of the milk hose with a brush.
8. Clean the suction filter with a twisted-in-wire brush.

15.2 Back up data



Back up the data if the machine is to be recommissioned later or if the machine is to be replaced by a machine of the same type.

This manual applies to coffee machines without Franke Digital Services.

1. In the service menu under Customization and data transfer, go to the menu item Go to Back up/load data.
 - ⇒ The machine data and the configuration will be saved on the USB stick.
2. Go to Back up/load data.
3. Connect the USB stick and Select Export.
 - 4. Tap Yes to eject the USB stick after the backup.

15.3 Short-term decommissioning (up to 3 weeks)

- ✓ The machine remains in place.
1. Clean the machine using the automatic cleaning function. **Cleaning [48]**
 2. Go to the energy-saving mode.
 3. Disconnect the machine from the power supply.
 4. Close the water supply if the machine has a main water connection.
 5. Clean any add-on units.
 6. Switch off the add-on units and disconnect them from the power grid.

15.4 Long-term decommissioning



NOTICE

Functionality of the machine is impaired in the event of long-term decommissioning and storage

If you plan to start using your machine again at a later date, it is essential that service measures are implemented. The coffee machine must be maintained, installed, and cleaned before preparing any beverages.

- a) Contact the Franke Service team for information regarding proper decommissioning and storage.
- b) Have your coffee machine drained by your service technician.
- c) Remedial maintenance may be required when commissioning the machine if it has been stored in excess of 6 months.

15.5 Transport and storage



Protect the machine from mechanical damage and adverse environmental conditions during transport and storage.

Transport conditions

Protect the machine from the following risks:

- Vibrations
- Dust
- Sunlight
- Falling or tipping over
- Slipping during transport
- Frost, if machine has not been drained and emptied completely

Storage conditions

- If the machine has been completely drained and emptied, it can be stored at -10 °C to 50 °C
- Relative humidity: max. 80 %
- It must be fixed in a suitably stable position throughout
- The machine should be in an upright position
- The machine should be empty and the system drained
- Machine and loose parts packaged, preferably in their original packaging

15.6 Recommissioning after prolonged periods of storage or non-use



NOTICE

Deterioration in storage

Parts may no longer function as they should if they have been stored or unused for periods in excess of 6 months.

- a) Contact your service technician for information regarding repairing and recommissioning your machine.

16 DISPOSAL OF PARTS

Disposal of consumables

- Beans, powder and coffee grounds can be composted.
- Observe the information on the label when disposing of any unused cleaning supplies.
- Dispose of the fluids from the cleaning container or the drip tray in the wastewater system.

Disposal of the machine and other devices



The appliance complies with European Directive 2012/19/EU regarding Waste Electrical and Electronic Equipment (WEEE) and must not be disposed of with household waste.



Dispose of electronic parts separately.



Dispose of plastic parts in accordance with their marking.



Two people are required for transporting the coffee machine.

17 TECHNICAL DATA

Device type	A300 (FCS4070)
Dimensions: Width/height/depth (mm)	340/465/587
Weight (kg)	25
Bean hopper capacity kg	Without bean hopper extension: 1 x 0,5/2 x 0,25 With bean hopper extension: 1x1,1/2x0,55
Powder hopper capacity (kg)	0,5/2x0,5
Noise emission (dB(A))	< 70
Ambient temperature (°C)	5-32
Humidity (%)	Max. 80
Water tank (l)	4,8

17.1 Capacities in accordance with DIN 18873-2:2016-02



This data assumes a main voltage of 230 V.

Hourly capacity	Single preparation (cups per hour)	Double preparation (cups per hour)
Espresso	124	163
Coffee/Café crème	80	92
Hot water (200 ml)	96	-
Cappuccino	91	130
Latte macchiato	96	116
Milk coffee	93	113
Chocolate	102	-

17.2 Electrical connection data

Voltage	Main power connection	Power rating (max.)	Fuse	Frequency
110–127 V	1LNPE	1200-1500 W	15 A	60 Hz
220–240 V	1LNPE	2100-2400 W	10 A	50-60 Hz

INDEX

Numeric

5-step method 12, 48

A

Access rights 64

Ambient conditions 78

B

Basic settings 33

Bean hopper 78

Beans

Disposal 77

Beverage

Preparing 45

C

Cancel button 12

Capacities 78

Care kit 54, 000, 000, 000

Cleaning 49

Drip grid 42

Drip tray 42

Cleaning container

Disposal of fluid 77

Cleaning supplies

Disposal 77

Cleaning tablets 16

Coffee beans

Filling 36

Storage 37

Coffee grounds

Disposal 77

Coffee machine

Cleaning 49

Unpacking 30

Connecting the water supply 30

Connection

electrical 32

Credit Mode 24

D

Dashboard 13

Decommissioning 75

Descaling 56

Due date 56

Performing 56

Determine water hardness 29

Dimension 26

Disposal 77

Drip grid 42

Drip tray 42

Disposal of fluid 77

E

Electronic parts

Disposal 77

Error message

Color code 15

Depiction 15

Error messages 70

F

Fitting

Water 30

Foam profiles

Setting 61

G

grind coarseness

Setting 40

I

Intended use 7

L

Lime deposits 11

M

Machine

Restarting 72

Switching on 32

Switching on for the first time 33

Main water connection		Steam output	47
Requirements	28	Steam wand	47
Version	22	Symbols	12
Manual set	16	Dashboard	13
Measuring cup	17	Instructions	13
Media		Software	13
Back up	68	T	
Loading	68	Tips	12
Milk		Transport	77
Filling	39	Troubleshooting	72
Milk spout	000	Machine error	70
Milk system cleaning agent		Type code	19, 20
Dosing bottle	16	Type plate	18
Minimum clearances	27	U	
O		User manual	16
Operating mode		W	
Non-self-service mode	70	Wastewater	31
Quick Select	24	Water quality	29
Self-service	70	Water tank	78
Operator panel	42	filling	38
P		Inserting the	38
PIN codes	58	Version	22
Plastic parts		Wipe protection	52
Disposal	77		
Powder			
Disposal	77		
Product quality	74		
R			
Requirements	12		
Resources			
filling	34		
Setting	60		
S			
Safety	8		
Screen			
Cleaning	52		
Wipe protection	52		
Setting beverages	60		
Spout	45		
Start button	13		



Franke Kaffeemaschinen AG

Franke-Str. 9
CH-4663 Aarburg
Switzerland
Tel. +41 62 787 31 31
www.franke.com

Franke Coffee Systems GmbH

Franke Strasse 1
97947 Grünsfeld
Deutschland
Tel.: +49 9346 9278 0
Fax: +49 9346 9278 100
www.franke.de

**Franke Coffee Systems
UK Limited**

6A Handley Page Way,
Old Parkbury Lane,
Colney Street,
St Albans,
Hertfordshire, AL2 2DQ
England
Tel.: +44 1923 635700
Fax: +44 1923 635701
www.franke.com

**Franke Coffee Systems
Americas**

800 Aviation Parkway
Smyrna, TN 37167
USA
Tel.: +1 615 462 4265
Fax: +1 615 462 4400
www.franke.com

coffee.franke.com